

# GE Profile Arctica® and GE CustomStyle™ side-by-side installation information & specifications

## Rough-in dimensions

### Standard, new construction and replacement installation

#### Installation tips to maximize the built-in look

- All wall/floor molding should be removed prior to installation.
- Water recess on rear wall recommended to prevent water line damage. 48" minimum length, 1/4"-diameter water line tubing recommended.
- When possible, recess both copper water line and electrical outlet (see local codes).
- Front and rear leveling legs are adjustable for the built-in look (see owner's manual).
- If optional collar trim kit is to be used or anticipated, see collar trim installation on next page for different rough-in dimensions.

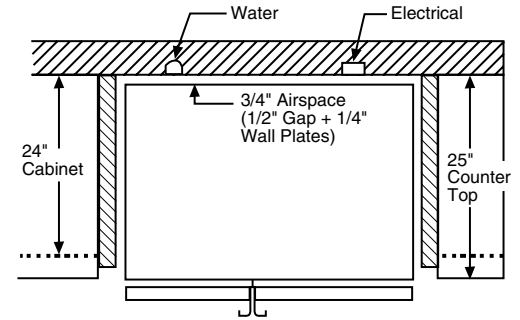
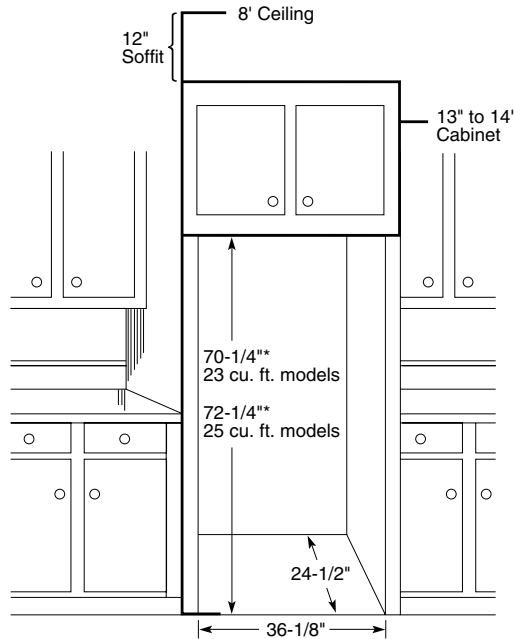

\*The rough-in dimensions of 70-1/4"/72-1/4" are minimum and measured from the finished floor to top of opening (or the underside of the overhead cabinets). For Models with Trim Kit: If frameless style cabinets are planned for above the refrigerator, you may need to consider adding a maximum of 1/4" (70-1/2") to height of opening for 23 cu. ft. models and 1/8" (72-3/8") for 25 cu. ft. models to allow additional clearance between cabinet doors and top of refrigerator trim when cabinet doors are in open position.

## Installation of water outlets

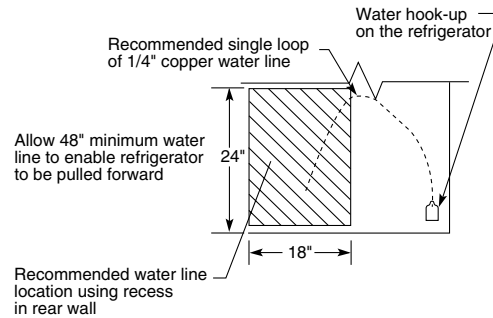
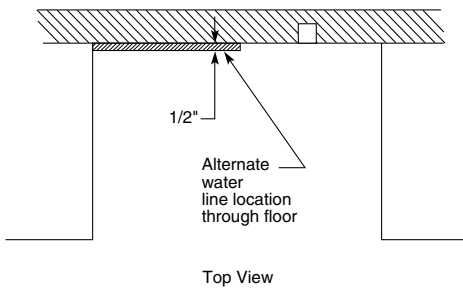

**IMPORTANT:** Before finalizing specifications for your GE Profile CustomStyle Refrigerator, please NOTE:

- A minimum width of 36" is required for refrigerator installation
- Be sure to allow for 1/2" or 3/4" side panels in addition to the 36" minimum

## Create a custom look for your GE Profile CustomStyle side-by-side refrigerator

Still another advantage offered by GE Profile CustomStyle Refrigerators is ease of installation. For a refrigerator that does so much to enhance the beauty of your kitchen, the "behind-the-scenes" preparation and installation are surprisingly simple.

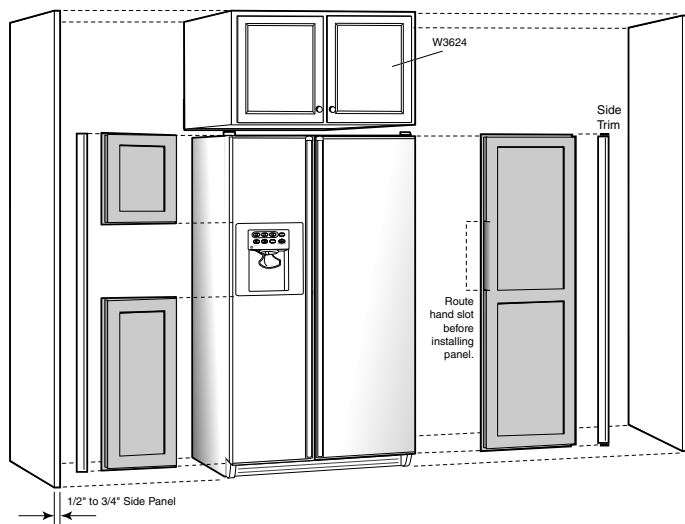

### Fabricating the enclosure

- The drawing shows an 84" cabinet elevation. Adjust dimensions accordingly for other cabinet elevations.
- Cabinet pieces to order: (2) side panels and (1) wall cabinet.
- Side panels will typically be attached to adjacent cabinets and/or cleated to rear wall and floor.
- Refer to GE refrigerator installation instructions for proper plumbing, and electrical and air clearances.
- (1) Some framed cabinet lines will make a refrigerator enclosure with a cabinet 12" high x 39" wide with sides and 1-1/2" face frame extended down to floor to create the refrigerator space. This will replace the above construction. (2) A tall cabinet on either side of the refrigerator can replace a side panel.
- Counter overhangs on either side of the refrigerator should have clipped corners to allow for full door swing.
- If the refrigerator has a wall returning beyond the front of the refrigerator on either side, a 2" tall filler will help allow for movement of the door.

### Door Panels

- See drawings for exact dimensions of the fresh-food and freezer door panels.
- Refrigerator door fronts from stock and most semi-custom cabinet manufacturers will be supplied as 1/4"-thick panels cut to dimensions, with closest available standard door sizes applied to front.
  - This will leave a "reveal" at top/bottom and sides. Width of "reveal" will depend on manufacturer's standard door sizes.
  - Door will be affixed on the 1/4" panels at factory or in the field by the local supplier, depending on manufacturer.
- Local shop-built or custom cabinet supplier may fabricate custom 3/4" panels. In this case, edges must be routed.
- Follow notes on drawing to assure room for fingers/hands to open handles.

## Door panel dimensions (in inches)

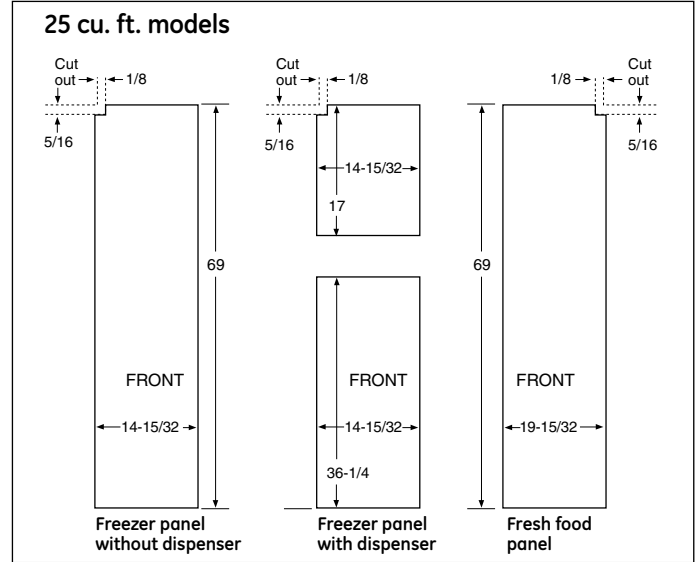
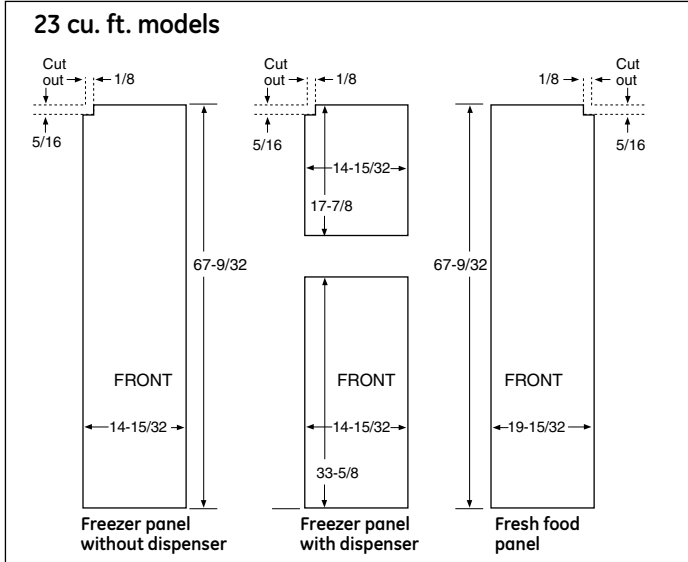

### Order your own custom wood panels to match cabinetry or other decor.

Panels up to 1/4" thick will fit door frame with no special preparation. Add filler behind material thinner than 1/4" for proper fit.

**Weight Limits:** Total weight of panels (i.e., both freezer panels)—Fresh Food = 38 lbs., Freezer = 28 lbs.

**Note:** Panels up to 3/4" will require special routing area around handles. Dimensions may vary depending on depth of panel.

### Detail C

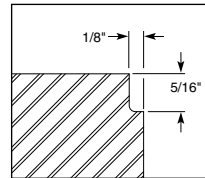

Notch required at top corner as noted.

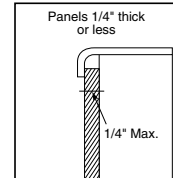

Fresh Food panel shown

## Collar trim installation

An enclosure is **required** to match up to the trim (see Typical Installation). To obtain the most integrated look, the cabinet or soffit above the refrigerator should extend out to the same depth as the side panels. The refrigerator opening must have minimum dimensions of 70-1/4" high x 36-1/8" wide x 24-1/2" deep for 23 cu. ft. models and 72-1/4" high x 36-1/8" wide x 24-1/2" for 25 cu. ft. models, as shown at right. If there is an overhead cabinet, allow 1" for cabinet door clearance with the top trim piece so the cabinet doors can be opened without hitting the top trim. If 1/2" side panels are used, then side trim and panel will be even. If 3/4" side panels are used, then some of the side panel will extend beyond the trim and must be finished.

**IMPORTANT:** Before finalizing specifications for your GE Profile CustomStyle Refrigerator, please NOTE:

- A minimum width of 36-1/8" is required for refrigerator installation with collar

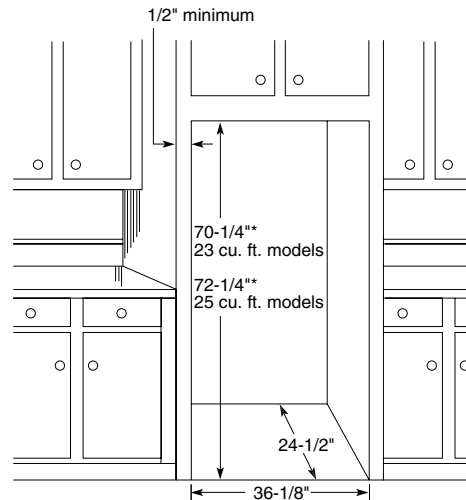

\*The rough-in dimensions of 70-1/4"/72-1/4" are minimum and measured from the finished floor to top of opening (or the underside of the overhead cabinets). For Models with Trim Kit: If frameless style cabinets are planned for above the refrigerator, you may need to consider adding a maximum of 1/4" (70-1/2") to height of opening for 23 cu. ft. models and 1/8" (72-3/8") for 25 cu. ft. models to allow additional clearance between cabinet doors and top of refrigerator trim when cabinet doors are in open position.

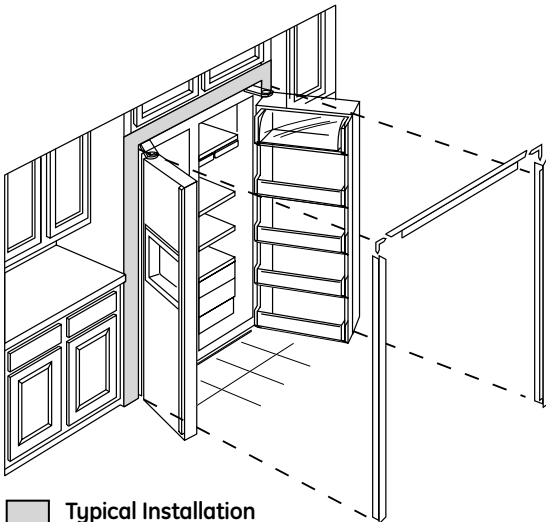

### Typical Installation

Shaded areas represent front surfaces of side panels and overhead cabinet or soffit that contacts trim.

