

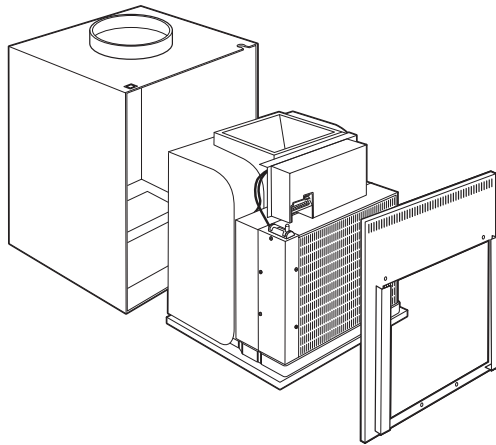

TECHNICAL SERVICE GUIDE

Zoneline Vertical Air Conditioners



MODEL SERIES:

- AZ75E09DAC
- AZ75H09DAC
- AZ75E09EAC
- AZ75H09EAC
- AZ75E12DAC
- AZ75H12DAC
- AZ75E12EAC
- AZ75H12EAC
- AZ75E18DAC
- AZ75H18DAC
- AZ75E18EAC
- AZ75H18EAC





IMPORTANT SAFETY NOTICE

The information in this service guide is intended for use by individuals possessing adequate backgrounds of electrical, electronic, and mechanical experience. Any attempt to repair a major appliance may result in personal injury and property damage. The manufacturer or seller cannot be responsible for the interpretation of this information, nor can it assume any liability in connection with its use.

WARNING

To avoid personal injury, disconnect power before servicing this product. If electrical power is required for diagnosis or test purposes, disconnect the power immediately after performing the necessary checks.

RECONNECT ALL GROUNDING DEVICES

If grounding wires, screws, straps, clips, nuts, or washers used to complete a path to ground are removed for service, they must be returned to their original position and properly fastened.

GE Consumer Home Services Training
Technical Service Guide
Copyright © 2002

All rights reserved. This service guide may not be reproduced in whole or in part in any form without written permission from the General Electric Company.

Table of Contents

Introduction	2
Nomenclature	3
Electrical Specifications	4
Technical Data	6
Features and Operation	8
ON/OFF Switch	8
Dip Switches	8
Main Board Terminal Strip	9
Remote Thermostat Control	10
Central Desk Control (CDC)	10
Temperature Limiting	11
Freeze Sentinel	11
Fan Speed (Indoor Fan)	12
Energy Management System	13
Door Sensor (kit)	13
Motion Sensor (kit)	14
Room Air Sensor (kit)	14
Automatic Defrosting of Indoor and Outdoor Coils	15
Ventilation Control	15
Cool Mode Operation	16
Heat Mode Operation	17
Slide-Out Chassis	18
Front Removal	18
Side Removal	18
Components	19
Main Board	19
Driver Board	19
Fuse	19
Sub Board	19
Compressor and Capacitor	20
Filter/Dryer	20
Resistance Heaters	22
Indoor Fan and Capacitor	25
Outdoor Fan and Capacitor	28
Reversing Valve	30
Transformer	32
Thermistors	33
Thermostatic Drain Valve	33
Dead Unit Troubleshooting	34
Schematics and Wiring Diagrams	36
Component Locator Views	40
Parts List	43
Care and Cleaning	51
Warranty	52

Introduction

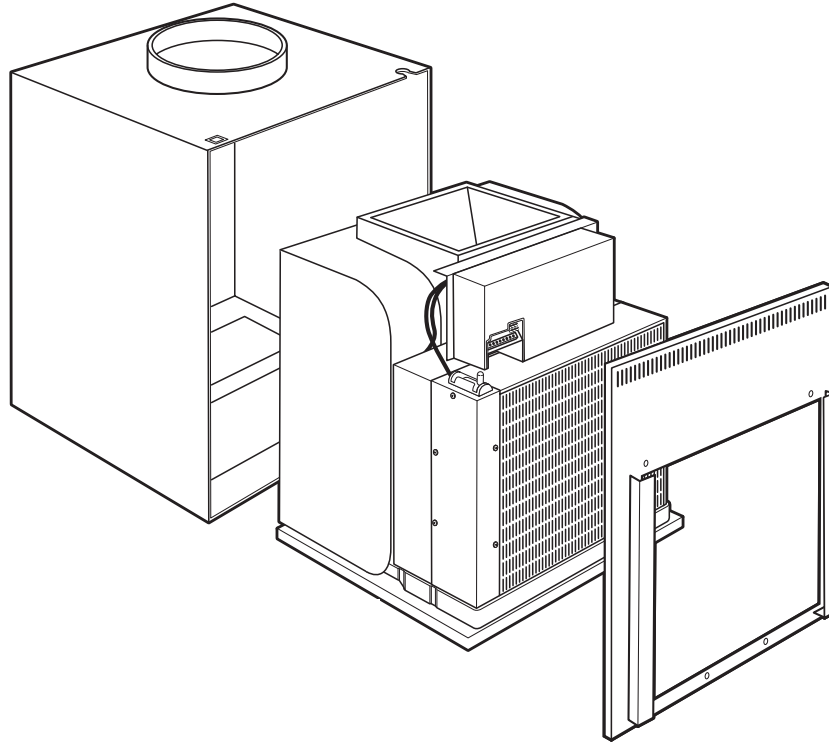

The new Zonline Vertical Air Conditioners are ideal for hotel/motel installations. Programmable for central desk control, electric heat, freeze sentinel, fan speed, and temperature limiting, these units allow for efficient control of power usage. The Energy Management System is also available, providing automatic comfort at peak energy efficiency.

The information on the following pages will help you service the Zonline Vertical Air Conditioners effectively and efficiently.

Nomenclature

Model Number

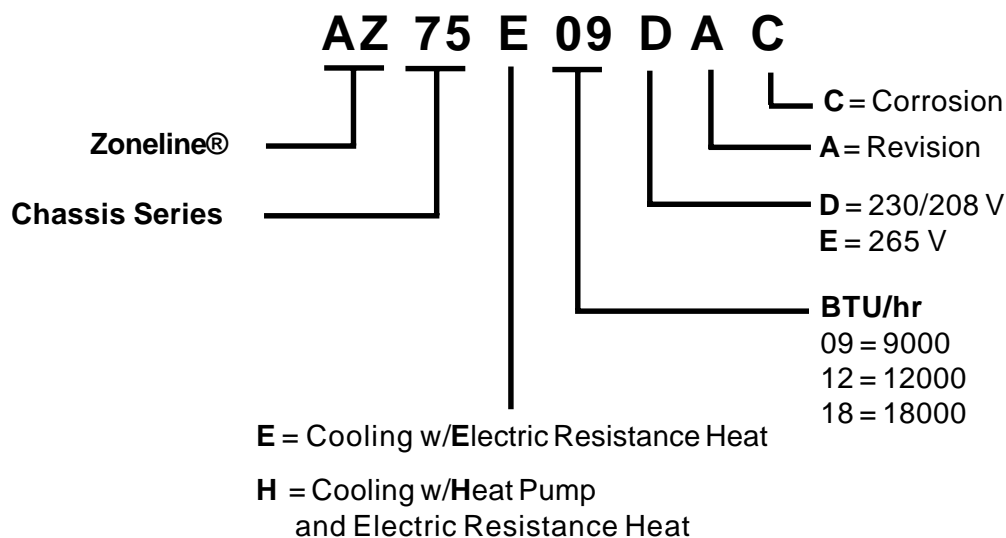

Model/Serial Tag Location



The model/serial tag is located on the front upper left-hand corner of the unit. This tag contains important information such as:

- Model/serial number
- Refrigerant charge
- Voltage rating
- Heat and cool amperes
- Heat resistance amperes
- BTU/hr

Serial Number

The first two characters of the serial number identify the month and year of manufacture.

Example: **AD**123456 = January, 2002

A - JAN	2005 - H
D - FEB	2004 - G
F - MAR	2003 - F
G - APR	2002 - D
H - MAY	2001 - A
L - JUN	2000 - Z
M - JUL	1999 - V
R - AUG	1998 - T
S - SEP	1997 - S
T - OCT	1996 - R
V - NOV	1995 - M
Z - DEC	1994 - L

The letter designating the year repeats every 12 years.

Example:

- T - 1974
- T - 1986
- T - 1998

Note: The technical sheet is located on the front left side of the unit under the model/serial tag.

Electrical Specifications

Wire Size and Breaker Size

Warning: All wiring, including installation of the receptacle, must be in accordance with the National Electric Code, local codes, ordinances, and regulations.

- Use only the wiring size recommended for single outlet branch circuit.
- Use only the type and size fuse of HACR circuit breaker indicated on the unit's rating plate. Proper current protection is the responsibility of the owner.

Recommended branch circuit wire sizes*	
Nameplate maximum circuit breaker size	AWG Wire size**
15A	14
20A	12
30A	10

AWG—American Wire Gauge
 * Single circuit breaker from main box
 ** Based on copper wire, single insulated conductor at 60° C

Note: Use copper conductors only.

Power Supply Kits



Tandem
15 Amp.

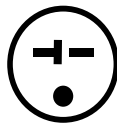

Perpendicular
20 Amp.



Large Tandem
30 Amp.

265/230/208 Volt Power Supply Kits	Wall Plug Configuration	Circuit Protective Device	Heater Wattage @ 230/208 volts
RAK3152	Tandem	15 Amp time Delay Fuse or Breaker	2.55/2.09 KW
RAK3202	Perpendicular	20 Amp time Delay Fuse or Breaker	3.45/2.82 KW
RAK3302	Large Tandem	30 Amp time Delay Fuse or Breaker	5.00/4.10 KW
RAK5157	Direct Connect	15 Amp time Delay Fuse or Breaker	2.55 KW
RAK5207	Direct Connect	20 Amp time Delay Fuse or Breaker	3.45 KW
RAK5307	Direct Connect	30 Amp time Delay Fuse or Breaker	5.00 KW

Direct Connection

208 VAC

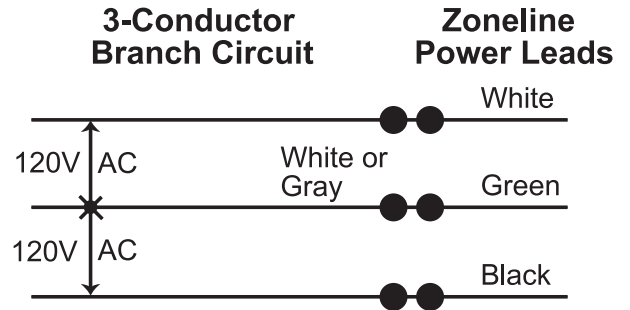
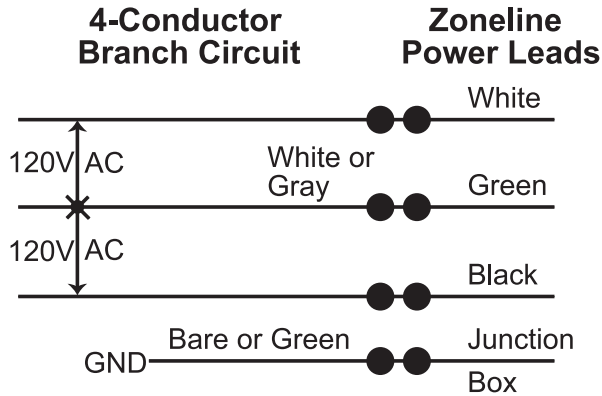

230 VAC

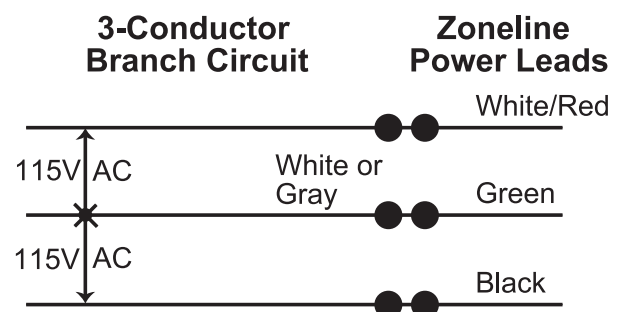
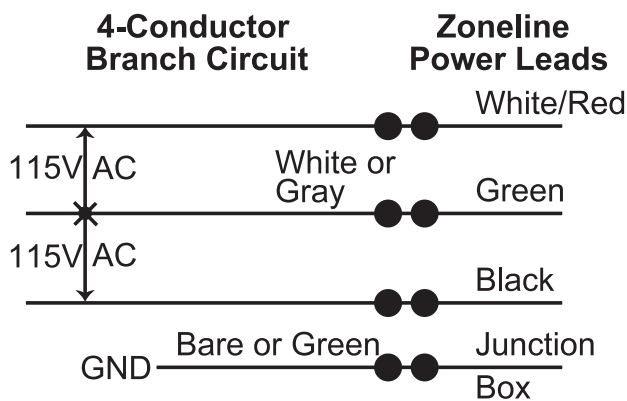

265 VAC

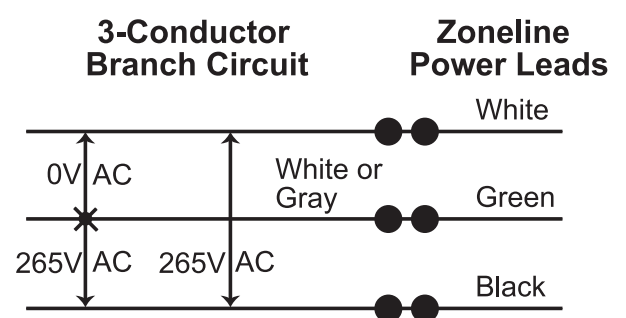
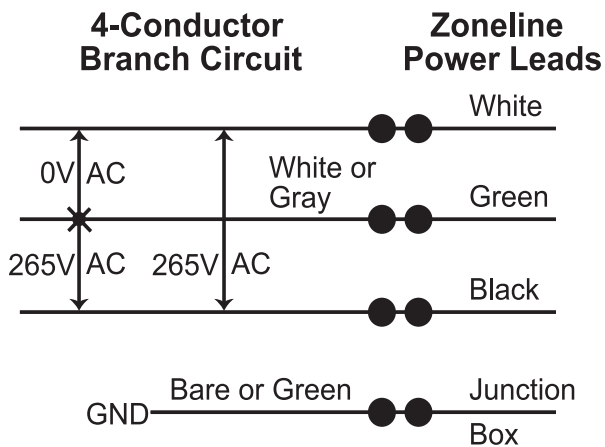

Technical Data

Heat Pump Model AZ75H12DAC

DISCONNECT POWER BEFORE SERVICING

IMPORTANT - RECONNECT ALL GROUNDING DEVICES

All parts of this appliance capable of conducting electrical current are grounded. If grounding wires, screws, straps, clips, nuts or washers used to complete a path to ground are removed for service, they must be returned to their original position and properly fastened.

WARNING DISCONNECT UNIT FROM ELECTRICAL POWER SUPPLY BEFORE MAKING ANY ELECTRICAL CHECKS.

MAXIMUM CURRENT LEAKAGE: 0.75 MILLIAMPS

MAXIMUM GROUND PATH RESISTANCE: 0.1 OHM

POWER SUPPLY

RATED VOLTAGE	VOLTAGE LIMITS
230/208	187-253

REPLACEMENT PARTS

DESCRIPTION	CAT. NO.
BLOWER (I.D.)	WJ73X10059
CAPACITOR, I.D. MOTOR	WJ20X10070
CAPACITOR, O.D. MOTOR	WP20X10005
CAPILLARY (4) (CUT TO 11 1/2")	WJ53X128
COMPRESSOR	WJ98X10006
CONDENSER	WJ88X10078
DRIVE PWB	WJ26X10071
EVAPORATOR	WJ87X10085
FAN (O.D.)	WJ73X10060
FILTER/DRYER	WJ56X104
FUSE, TRANSFORMER PRIMARY	WJ23X10003
HEATER ASSEMBLY	WJ70X10038
MAIN PWB	WJ26X10070
MOTOR, BLOWER (I.D.)	WJ73X10062
MOTOR, FAN (O.D.)	WJ73X10061
PROTECTOR, COMPRESSOR	WP23X10005
PROTECTOR, HEATER-1 (resettable)	WP28X10005
PROTECTOR, HEATER-2 (one-time)	WP28X10007
REVERSING VALVE	WJ58X10020
REVERSING VALVE COIL	WJ31X10011
RUN CAPACITOR	WJ20X748
SUB PWB	WJ26X10072
THERMISTOR	WJ28X10027
TRANSFORMER	WP27X10023
VARISTOR	WP27X10002

°F	SENSOR RESISTANCE (OHM)		
	INDOOR COIL	OUTDOOR COIL	OUTDOOR AIR
10	94900	28030	28030
30	51940	15340	15340
32	49330	14570	14570
50	29960	8850	8850
70	17930	5300	5300
90	10970	3280	3280

FILTER

Check for cleanliness.

CONDENSER

1. Check for blockage with dirt, or other material.
2. Check for corrosion.

WIRING - COMPRESSOR DIRECT CHECK

CAUTION:

1. Keep head clear of terminal area when cover is removed.
2. Check windings first. If open or grounded, "DO NOT" apply power to compressor terminals.

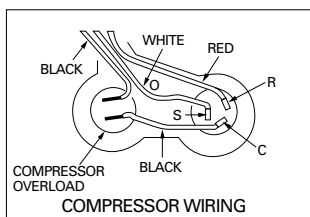

IMPORTANT SAFETY NOTICE

This information is intended for use by individuals possessing adequate backgrounds of electrical, electronic and mechanical experience. Any attempt to repair a major appliance may result in personal injury and property damage. The manufacturer or seller cannot be responsible for the interpretation of this information, nor can it assume any liability in connection with its use.

RUNNING CURRENT

With unit in case, operate for ten minutes on Hi-Cool. Following are the operating limits:

CURRENT-TEMPERATURE CHECK DATA

AIR TEMPERATURE CONDENSER IN °F	COOLING CURRENT			
	230V-MIN. MAX.		208V-MIN. MAX.	
80	4.6	5.0	4.8	5.3
95	5.3	5.9	5.5	6.1
110	6.2	6.9	6.8	7.6

TEMPERATURE DIFFERENTIAL - COOLING

Unit must operate for one hour with thermostat at coldest setting prior to measuring air temperatures. Following are the normal limits:

TEMPERATURE DIFFERENTIAL CHECK DATA

EVAPORATOR AIR TEMPERATURE IN °F	EVAPORATOR AIR TEMPERATURE OUT °F			
	230V-MIN. MAX.		208V-MIN. MAX.	
70	48	52	46	50
80	58	62	58	62
90	65	69	65	69

RUNNING CURRENT

With unit in case, operate for ten minutes on Hi-Heat. Following are the operating limits:

CURRENT-TEMPERATURE CHECK DATA

AIR TEMPERATURE OUTDOOR COIL IN °F	REVERSE CYCLE HEATING CURRENT			
	230V-MIN. MAX.		208V-MIN. MAX.	
47	4.0	4.4	4.1	4.5
60	4.3	4.8	4.6	5.1
75	4.6	5.0	4.9	5.4

TEMPERATURE DIFFERENTIAL - HEATING

Unit must operate for one hour in reverse cycle heating prior to measuring air temperatures. Following are the normal limits:

TEMPERATURE DIFFERENTIAL CHECK DATA

INDOOR COIL AIR TEMPERATURE IN °F	INDOOR COIL AIR TEMPERATURE OUT °F			
	230V-MIN. MAX.		208V-MIN. MAX.	
70	89	93	91	95
75	98	102	100	104
80	106	110	108	112

RUN CAPACITOR CHECK

1. Replace unit run capacitor with a known good test capacitor which may be 10 MFD higher than specified and attempt to start compressor.
2. If compressor starts, install a new run capacitor which has a rating specified for the unit.

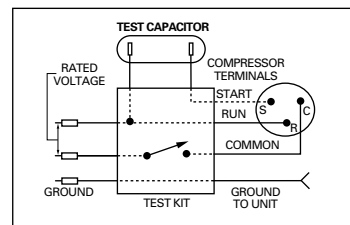

Electric Resistance Heat Model AZ75E12DAC

DISCONNECT POWER BEFORE SERVICING

IMPORTANT - RECONNECT ALL GROUNDING DEVICES

All parts of this appliance capable of conducting electrical current are grounded. If grounding wires, screws, straps, clips, nuts or washers used to complete a path to ground are removed for service, they must be returned to their original position and properly fastened.

WARNING DISCONNECT UNIT FROM ELECTRICAL POWER SUPPLY BEFORE MAKING ANY ELECTRICAL CHECKS.

MAXIMUM CURRENT LEAKAGE: 0.75 MILLIAMPS
MAXIMUM GROUND PATH RESISTANCE: 0.1 OHM

POWER SUPPLY

RATED VOLTAGE	VOLTAGE LIMITS
230/208	187-253

REPLACEMENT PARTS

DESCRIPTION	CAT. NO.
BLOWER (I.D.)	WJ73X10059
CAPACITOR, I.D. MOTOR	WP20X10070
CAPACITOR, O.D. MOTOR	WP20X10005
CAPILLARY (2) (CUT TO 21")	WJ53X128
COMPRESSOR	WJ98X10006
CONDENSER	WJ88X10079
DRIVE PWB	WJ26X10073
EVAPORATOR	WJ87X10085
FAN (O.D.)	WJ73X10060
FILTER/DRYER	WJ56X104
FUSE, TRANSFORMER PRIMARY	WP23X10003
HEATER ASSEMBLY	WJ70X10038
MAIN PWB	WJ26X10070
MOTOR, BLOWER (I.D.)	WJ73X10062
MOTOR, FAN (O.D.)	WJ73X10061
PROTECTOR, COMPRESSOR	WP23X10005
PROTECTOR, HEATER-1 (resettable)	WJ28X10005
PROTECTOR, HEATER-2 (one-time)	WJ28X10007
RUN CAPACITOR	WJ20X748
SUB PWB	WJ26X10072
THERMISTOR	WJ28X10028
TRANSFORMER	WP27X10023
VARISTOR	WP27X10002

°F	SENSOR RESISTANCE (OHM)	
	INDOOR COIL	
10	94900	
30	51940	
32	49330	
50	29960	
70	17930	
90	10970	

FILTER

Check for cleanliness.

CONDENSER

1. Check for blockage with dirt, or other material.
2. Check for corrosion.

IMPORTANT SAFETY NOTICE

This information is intended for use by individuals possessing adequate backgrounds of electrical, electronic and mechanical experience. Any attempt to repair a major appliance may result in personal injury and property damage. The manufacturer or seller cannot be responsible for the interpretation of this information, nor can it assume any liability in connection with its use.

RUNNING CURRENT

With unit in case, operate for ten minutes on Hi-Cool. Following are the operating limits:

CURRENT-TEMPERATURE CHECK DATA

AIR TEMPERATURE CONDENSER IN °F	COOLING CURRENT			
	230V-MIN. MAX.		208V-MIN. MAX.	
80	4.6	5.0	4.8	5.3
95	5.3	5.9	5.5	6.1
110	6.2	6.9	6.8	7.6

TEMPERATURE DIFFERENTIAL - COOLING

Unit must operate for one hour with thermostat at coldest setting prior to measuring air temperatures. Following are the normal limits:

TEMPERATURE DIFFERENTIAL CHECK DATA

EVAPORATOR AIR TEMPERATURE IN °F	EVAPORATOR AIR TEMPERATURE OUT °F			
	230V-MIN. MAX.		208V-MIN. MAX.	
70	48	52	46	50
80	58	62	58	62
90	65	69	65	69

RUN CAPACITOR CHECK

1. Replace unit run capacitor with a known good test capacitor which may be 10 MFD higher than specified and attempt to start compressor.
2. If compressor starts, install a new run capacitor which has a rating specified for the unit.

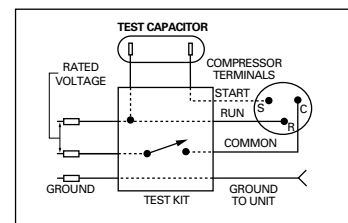

WIRING - COMPRESSOR DIRECT CHECK

CAUTION:

1. Keep head clear of terminal area when cover is removed.
2. Check windings first. If open or grounded, "DO NOT" apply power to compressor terminals.

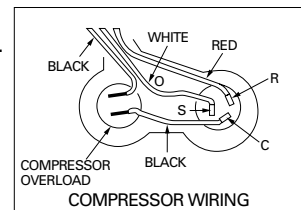

Features and Operation

ON/OFF Switch

Warning: ON/OFF switch does not disconnect power from all circuits.

The ON/OFF switch is located on the electronics cover behind the front case panel. The ON/OFF switch disables all relays but does not disconnect power from all circuits. No functions are available when the switch is off.

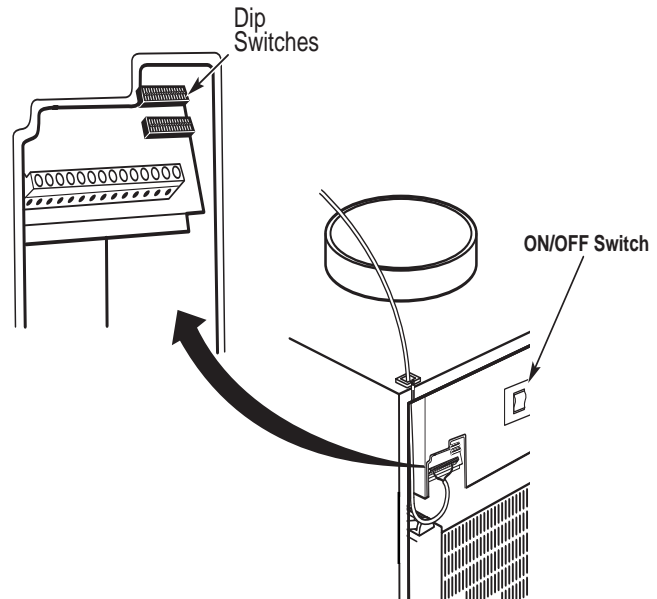

Dip Switches

The dip switches are located behind the front case panel, through an opening on the front of the unit. The top row of dip switches control Temperature Limiting. The bottom row of dip switches control the heat pump lockout, Freeze Sentinel, constant fan, Energy Management System, and indoor fan speed.

The dip switches will be set in the down position from the factory.

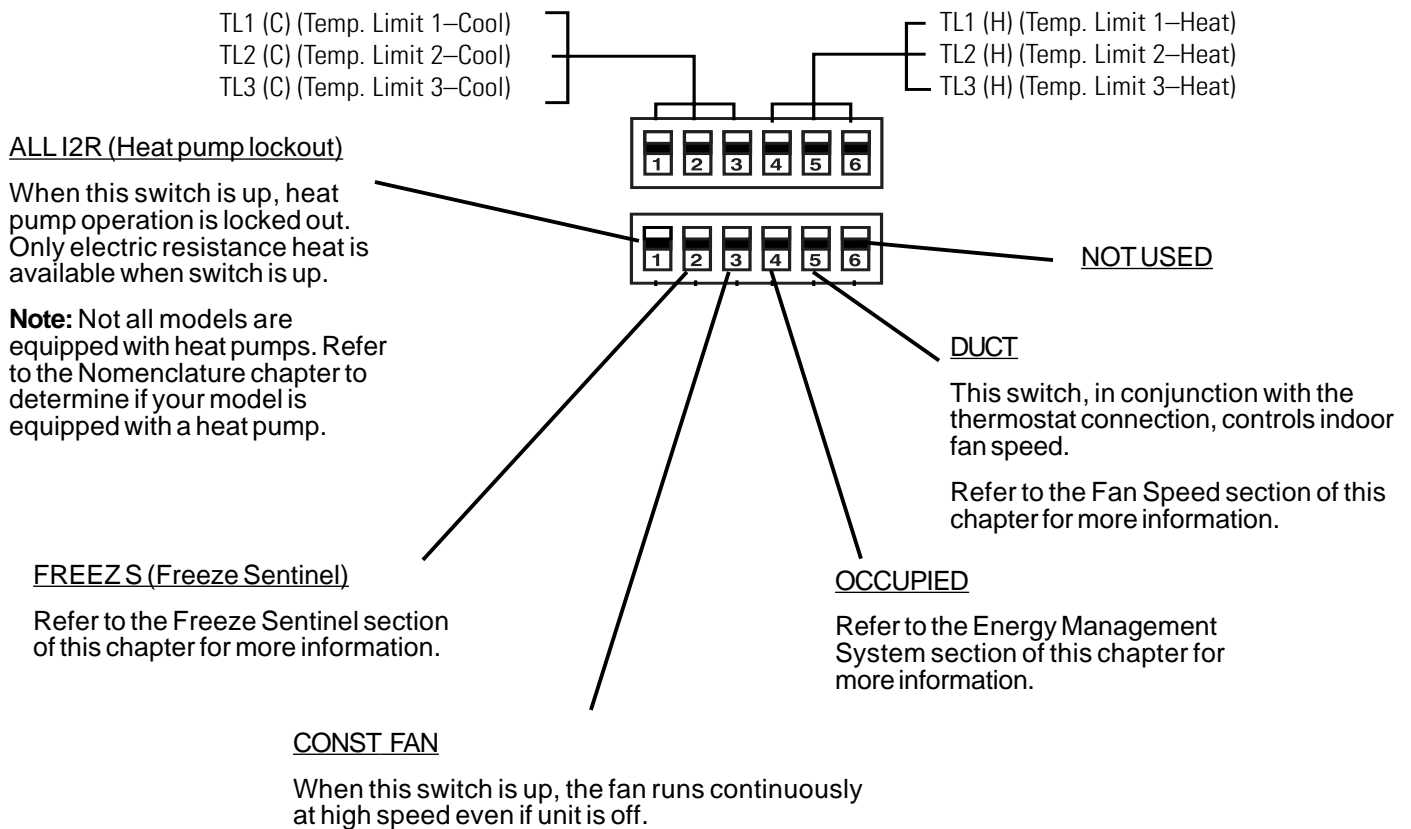

Main Board Terminal Strip

Caution: Improper wiring may damage the Zoneline electronics. Damage or erratic operation may result. No common bussing is permitted. A separate wire pair must be run from each separate controlling switch to each individual Zoneline.

The terminal connections are located behind the front case panel.

Insert the building hookup wires into the bottom of the terminal and tighten screw securely to make the desired connections.

Route any wires from the terminal connections through the case loop.

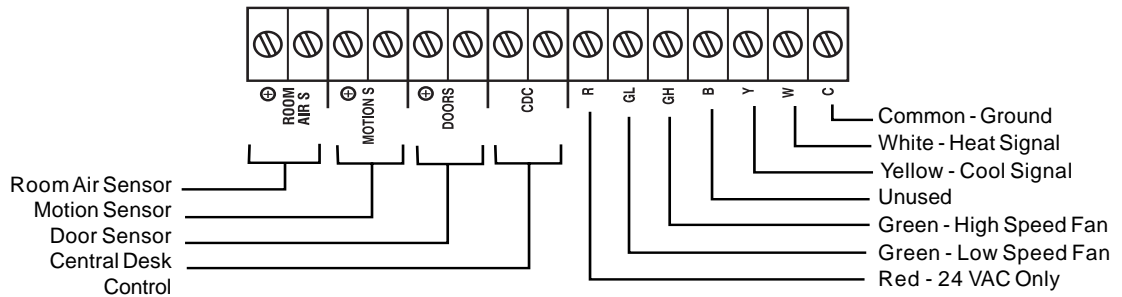
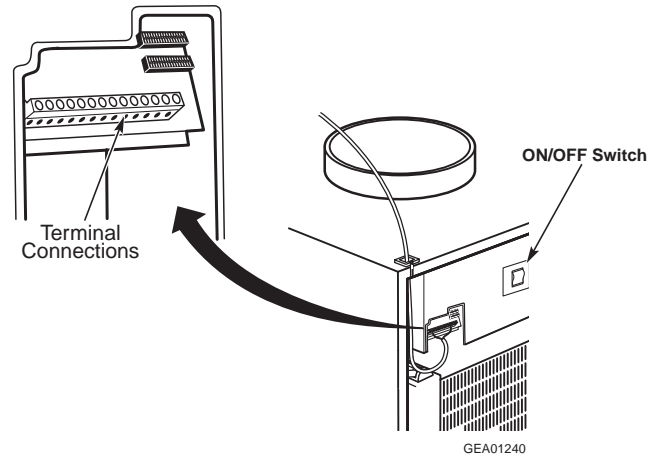

Remote Thermostat Control

The unit is controlled by an externally mounted, remote thermostat.

The Zoneline thermostat connections provide 24 VAC only. If using a digital/electronic wall thermostat, it must be set to the 24 VAC setting. Refer to the thermostat installation instructions for details.

Note: Some thermostats can be programmed to energize the reversing valve in heating mode or cool mode. If the thermostat is not programmed correctly, the unit will heat when the thermostat is set to cool and cool when the thermostat is set to heat. Refer to the instructions provided with the thermostat for thermostat programming procedures. Also refer to the Reversing Valve section of the Components chapter for more information.

Central Desk Control (CDC)

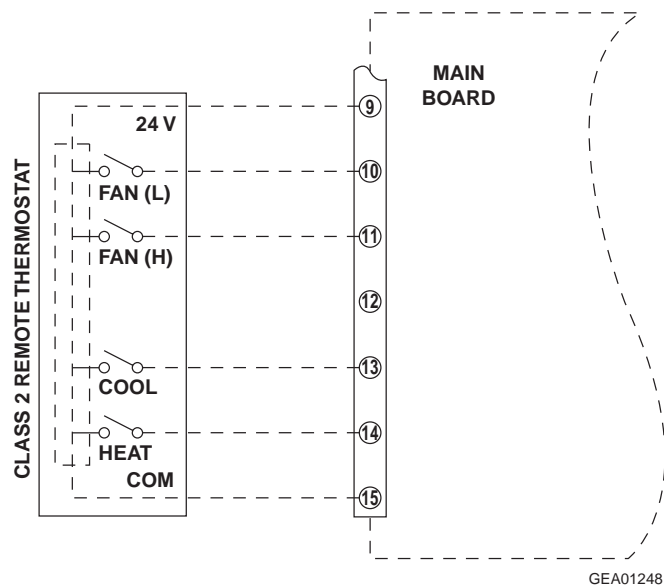
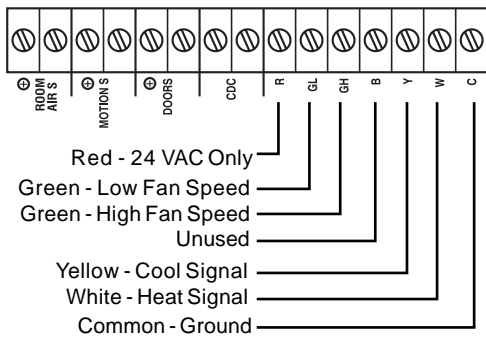

When a CDC switch is connected to the main board terminal strip, the unit can be turned on and off from a remote location. Up to 2000 feet of wire may be used to connect a remote CDC switch to the unit.

A separate wire pair must be run from each CDC switch to each Zoneline. Multiple units cannot be run from the same CDC switch.

The remote CDC switch will be closed when the unit is off.

REMOTE CDC SWITCH CLOSED = UNIT OFF

REMOTE CDC SWITCH OPEN = UNIT ON

Note: The Freeze Sentinel is still operational when the remote CDC switch has turned the unit off (room air sensor must be installed and Freeze Sentinel dip switch must be in the down position for the Freeze Sentinel to operate).

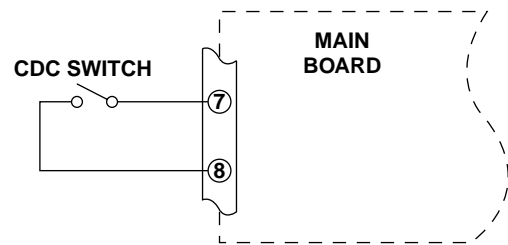
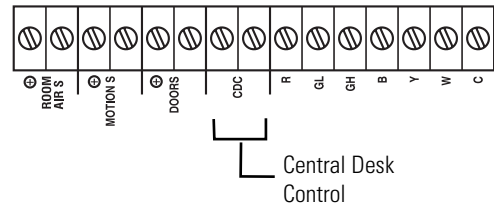

GEA01218

Temperature Limiting

Temperature limiting limits the lowest temperature that can be set for cooling and the highest temperature that can be set for heating. The dip switches are used to control temperature limiting.

Temperature limiting is dependent on the Room Air Sensor (kit). If the Room Air Sensor (kit) is not installed, temperature limiting will not operate. Temperature limiting is not dependent on the Occupied dip switch, Motion Sensor (kit), or Door Sensor (kit).

Freeze Sentinel

TL1 (C) (Temp. Limit 1–Cool)
 TL2 (C) (Temp. Limit 2–Cool)
 TL3 (C) (Temp. Limit 3–Cool)

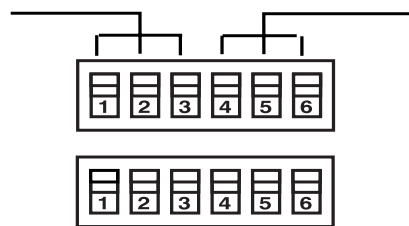

TL1 (H) (Temp. Limit 1–Heat)
 TL2 (H) (Temp. Limit 2–Heat)
 TL3 (H) (Temp. Limit 3–Heat)

Temperature Limiting During Cool Mode			
Up	Down	Minimum	Maximum
None	1, 2, 3	60 °F	85 °F
1	2, 3	64 °F	85 °F
1, 2	3	66 °F	85 °F
2	1, 3	68 °F	85 °F
2, 3	1	70 °F	85 °F
1, 2, 3	None	72 °F	85 °F
1, 3	2	74 °F	85 °F
3	1, 2	76 °F	85 °F

Temperature Limiting During Heat Mode			
Up	Down	Minimum	Maximum
None	4, 5, 6	60 °F	85 °F
4	5, 6	60 °F	80 °F
4, 5	6	60 °F	78 °F
5	4, 6	60 °F	76 °F
5, 6	4	60 °F	74 °F
4, 5, 6	None	60 °F	72 °F
4, 6	5	60 °F	70 °F
6	4, 5	60 °F	65 °F

The Freeze Sentinel is enabled by a dip switch and is dependant on the Room Air Sensor (kit). If the Room Air Sensor (kit) is not installed, the Freeze Sentinel will not operate. The FREEZE S dip switch must be down for Freeze Sentinel operation.

FREEZE S SWITCH DOWN = ON

FREEZE S SWITCH UP = OFF

The Freeze Sentinel turns on the resistance heater(s) and indoor fan when the Room Air Sensor (kit) sees 41 °F. When the temperature of the room has risen to 46 °F, the unit will turn off.

The Freeze Sentinel will remain enabled when the unit has been turned off by the remote Central Desk Control.

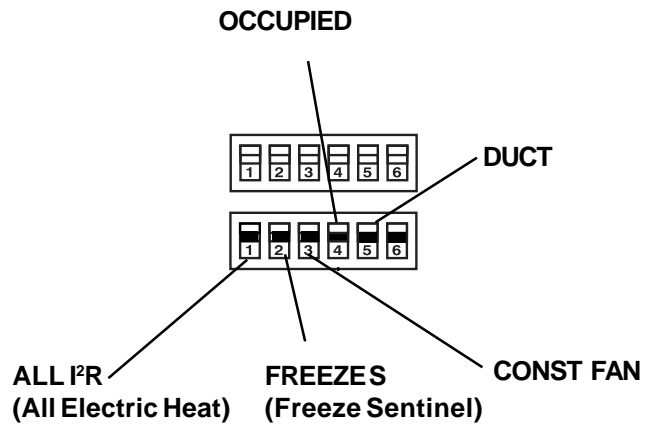

Fan Speed (Indoor Fan)

The Indoor fan operates at one speed during unit operation. The duct dip switch, in conjunction with the thermostat connection, controls at what speed the indoor fan operates.

When the green thermostat wire is connected to the high speed fan (GH) terminal:

DUCT SWITCH UP = HIGH FAN SPEED

DUCT SWITCH DOWN = MEDIUM FAN SPEED

When the green thermostat wire is connected to the low speed fan (GL) terminal:

DUCT SWITCH UP = MEDIUM FAN SPEED

DUCT SWITCH DOWN = LOW FAN SPEED

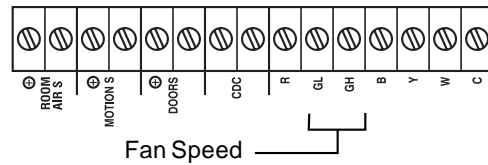

Energy Management System

The following conditions must exist for the Energy Management System to operate:

- OCCUPIED dip switch is up.
- Room Air Sensor (kit) is installed.
- Door Sensor (kit) is installed.
- Motion Sensor (kit) is installed.

The Energy Management System uses input from the Door Sensor (kit) and Motion Sensor (kit) to establish if the room is occupied or unoccupied. When the Energy Management System has established that the room is unoccupied, it uses input from the Room Air Sensor (kit) and allows the temperature of the room to lower to 68 °F (heat mode) or raise to 78 °F (cool mode). When the room becomes occupied, the Energy Management System will return to thermostat-controlled operation and will return the room to the temperature set on the thermostat.

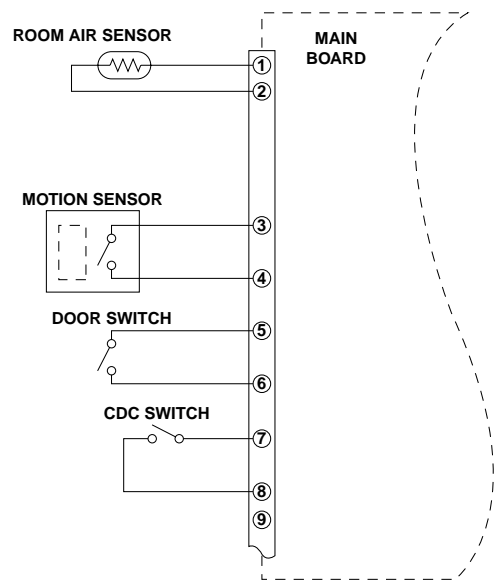

Schematic shown with unit on, door closed, and motion sensed. GEA01211

Door Sensor (kit)

The door sensor has a two-wire circuit that is connected to the main board terminal strip. When the door opens, the door sensor (switch) closes.

When the Energy Management System sees the door sensor circuit close (door opened), the Energy Management System will then check the motion sensor circuit.

Note: The Energy Management System is dependent on the Room Air Sensor, Motion Sensor, and Door Sensor. If the Room Air Sensor, Motion Sensor, and Door Sensor are not installed, the Energy Management System will not operate.

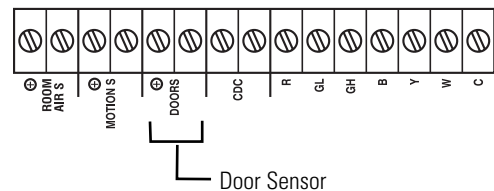

DOOR OPEN = SENSOR (SWITCH) CLOSED

DOOR CLOSED = SENSOR (SWITCH) OPEN

**MAIN BOARD OUTPUT TO
DOOR SENSOR = 24 VAC**

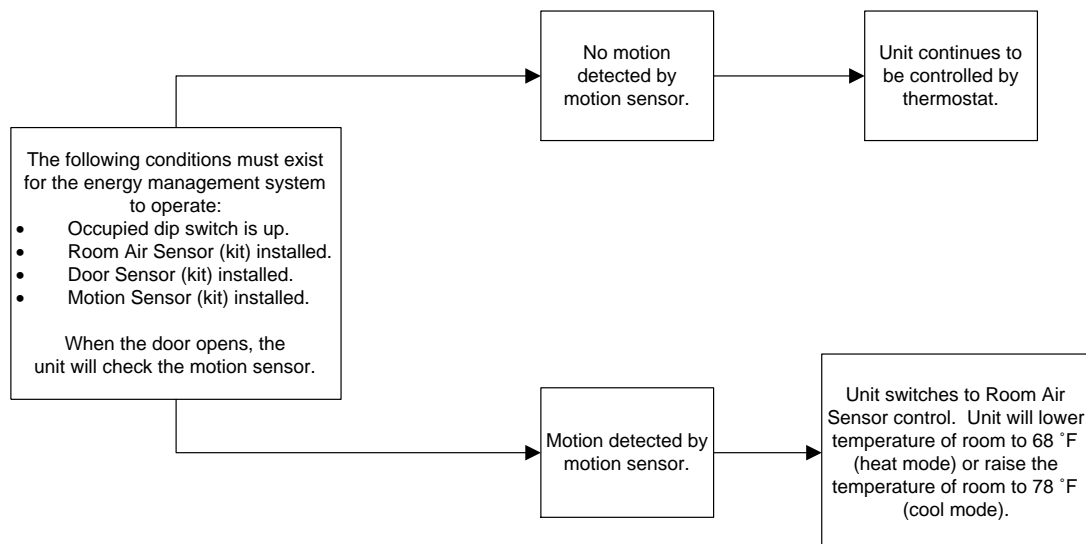

Motion Sensor (kit)

The motion sensor has a 2-wire circuit that is connected to the main board terminal strip. The motion sensor is an electronic sensor that, when motion is sensed, closes a switch (internal to the sensor), completing the motion sensor circuit.

After the Energy Management System has seen the door sensor circuit closed (door opened), it will check the motion sensor circuit. If the Energy Management System sees the motion sensor circuit closed (no motion detected by the sensor), it will then check the temperature being reported by the room air sensor. If the Energy Management System sees the motion sensor circuit open (motion detected by sensor), the unit will continue to be thermostat-controlled.

Note: The Energy Management System is dependent on the Room Air Sensor, Motion Sensor, and Door Sensor. If the Room Air Sensor, Motion Sensor, and Door Sensor are not installed, the Energy Management System will not operate.

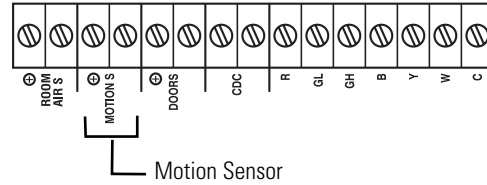

NO MOTION = SENSOR (SWITCH) CLOSED

MOTION = SENSOR (SWITCH) OPEN

**MAIN BOARD OUTPUT TO
MOTION SENSOR = 24 VAC**

Room Air Sensor (kit)

The room air sensor is a thermistor with a negative coefficient (as temperature rises, resistance goes down). The sensor has a 2-wire circuit that is connected to the main board terminal strip.

The room air sensor is used for Temperature Limiting and for the Energy Management System.

When the Energy Management System sees the door sensor circuit close and then the motion sensor circuit close (room unoccupied), the Energy Management System will ignore the thermostat and check the temperature reported by the room air sensor. Based on the input from the room air sensor, the Energy Management System will allow the temperature of the room to lower to 68 °F (heat mode) or raise to 78 °F (cool mode).

Note: The Energy Management System is dependent on the Room Air Sensor, Motion Sensor, and Door Sensor. If the Room Air Sensor, Motion Sensor, and Door Sensor are not installed, the Energy Management System will not operate.

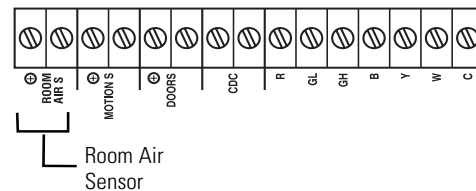

**MAIN BOARD OUTPUT TO
ROOM AIR SENSOR = 5 VDC**

Room Air Sensor Resistance Values	
Temperature	Resistance
32 °F	60 kΩ
68 °F	20 kΩ
77 °F	10 kΩ
86 °F	9 kΩ
95 °F	8 kΩ

Automatic Defrosting of Indoor and Outdoor Coils

During continued compressor operation, there is potential for ice to form on the indoor coil when in cool mode and for ice to form on the outdoor coil when in heat mode. The Zoneline is equipped with Automatic Defrost to eliminate this potential problem.

Indoor coil defrost will occur when the indoor coil thermistor reads a temperature of 34 °F or less for a duration of 5 minutes. The main board will automatically shut the compressor off, allowing the indoor coil temperature to rise. The fans will continue to operate throughout the defrost cycle for continued air circulation. When the indoor coil thermistor detects a temperature of 50 °F or above, the compressor will resume normal operation. A 3-minute minimum compressor off time will be in effect.

Outdoor coil defrost will occur for one of the following reasons:

- The outdoor temperature thermistor reads a temperature of 14 °F or less for a duration of 2 hours and 59 minutes.
- The accumulated run time of the compressor is greater than 3 hours with an outdoor temperature of 32 °F or less.

The outdoor coil is defrosted by reverse cycle defrosting (reversing the direction of the refrigerant flowing through the sealed system). This will cause hot refrigerant flowing through the outdoor coil to quickly and efficiently melt any ice that has formed. Outdoor coil defrosting will terminate when the outdoor coil thermistor reads a temperature of 68 °F or when a period of 9 minutes has elapsed, whichever comes first. When outdoor defrosting has been completed, the resistance heater(s) and fans will run for a minimum of 90 seconds or until the room has reached the thermostat set point.

Ventilation Control

The ventilation control lever is located on the left side of the Zoneline unit, behind the front case panel.

When the lever is in the **CLOSE** position, only air inside the room is circulated and filtered.

When the lever is in the **OPEN** position, some outdoor air will be drawn into the room. This will reduce the heating or cooling efficiency.

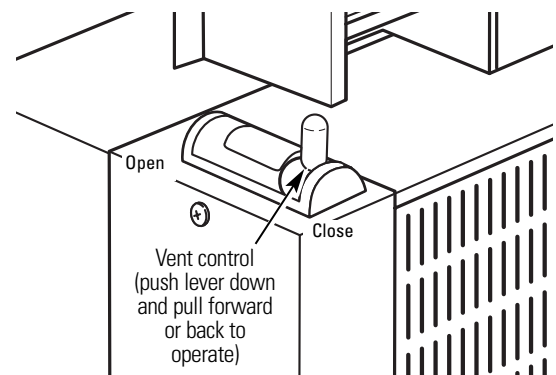

Cool Mode Operation

Note:

- Minimum compressor/fans off time is 3 minutes +/- 10 seconds.
- Reversing valve is energized at all times in cool mode. Reversing valve is not de-energized when thermostat is satisfied.
- Indoor and outdoor fans always operate at the same time in cool mode.

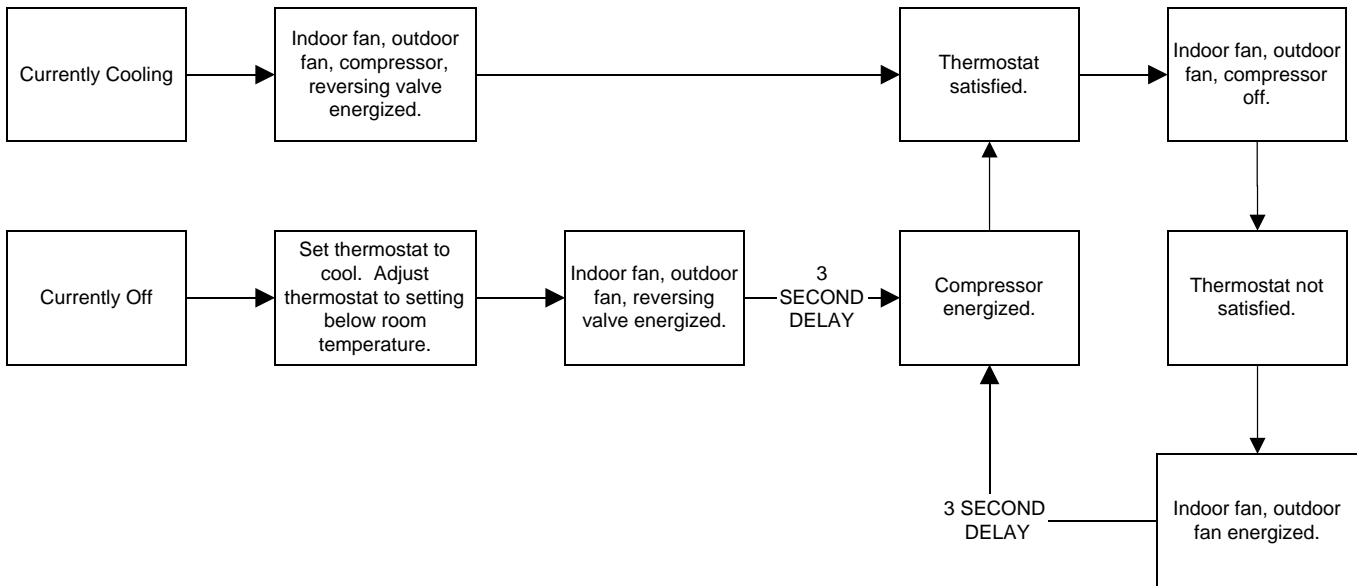

Heat Mode Operation

Note:

- Minimum compressor/fans off time is 3 minutes +/- 10 seconds.
- Heat pump will not operate if outdoor thermistor sees 25 °F or less.
- Heat pump and resistance heater(s) do not operate at the same time.
- Indoor and outdoor fans operate at the same time, with the following exception: Should the indoor coil temperature reach 131 °F, the outdoor fan will stop until the indoor coil temperature lowers to 126 °F.

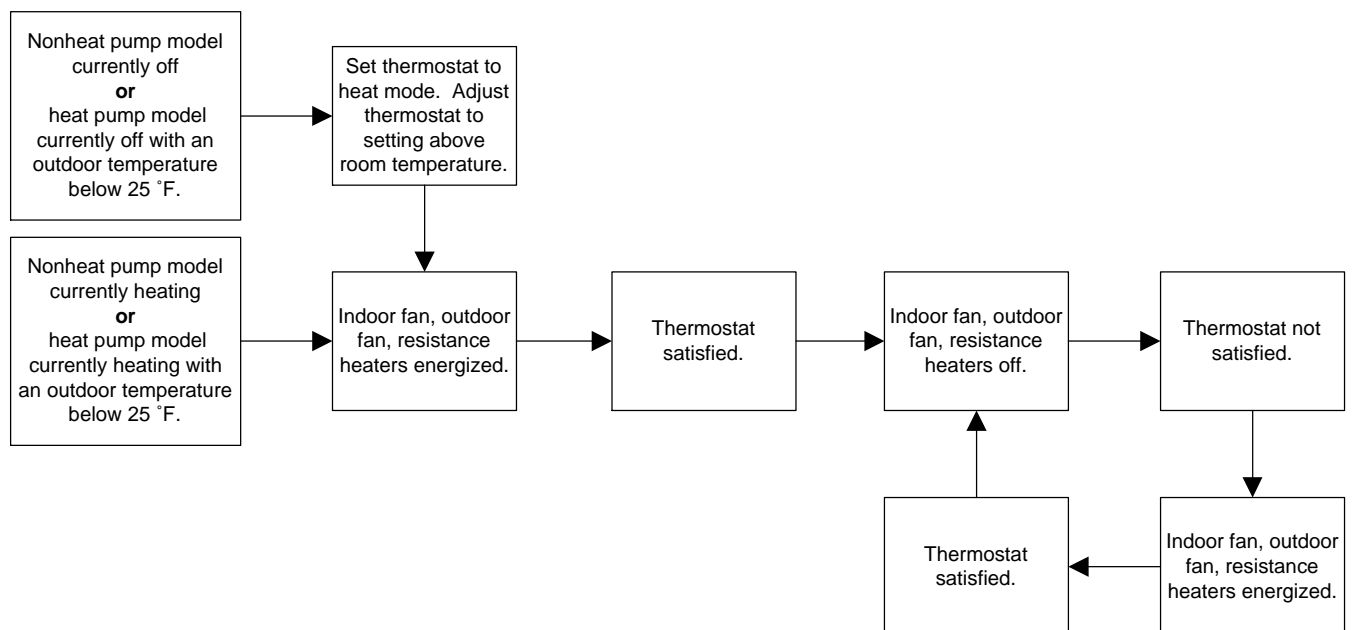
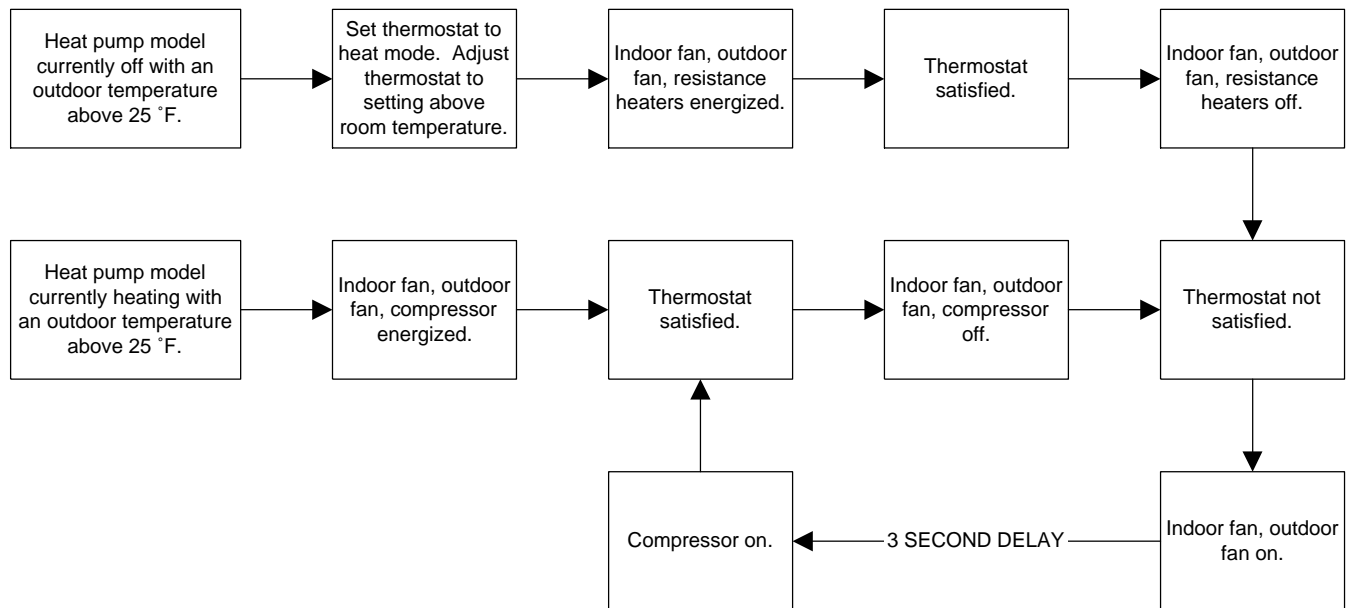

Slide-Out Chassis

WARNING: Case ground bolt at front of chassis must be installed to ensure proper grounding of the unit. Case ground screw on left hand cabinet side plate and/or right hand cabinet side plate must be installed to ensure proper grounding of the unit.

Front Removal

1. Remove 6 screws and the front panel.
2. Remove the 5/16-in. (case ground) bolt fastening the chassis to the base of the cabinet.
3. Remove the case ground screw from the left-hand side cabinet side plate and/or the right-hand cabinet side plate.
4. Turn 4 screws on the cabinet top plate counterclockwise to the raise duct connector to stop.
5. Slide the chassis out of the cabinet.



Side Removal

Note: If slide-out chassis cannot be removed from the front, perform the first 4 steps of Front Removal above and proceed with Side Removal below.

1. Remove 8 screws and the cabinet side plate.
2. Move the chassis out of the front of the cabinet approximately 2 inches.
3. Slide the chassis out from the side of the cabinet.

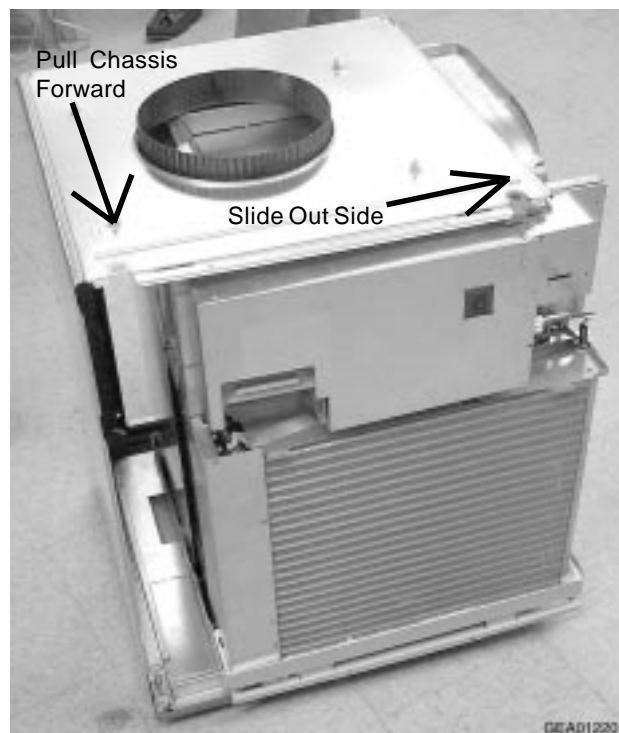

Components

Main Board

To access the main board:

1. Remove 6 screws and the front panel.
2. Unplug the heater connector.

WARNING: Do not touch the capacitors after the electronics cover is removed.

Caution: When removing electronics cover, pull the right side out a few inches to avoid damage to the switch wires.

3. Remove 4 screws from the electronics cover.
4. Lift the electronics cover to access the sub board. Unplug the ON/OFF switch from the sub board at connector CN202 and remove the cover.

Electronics Cover

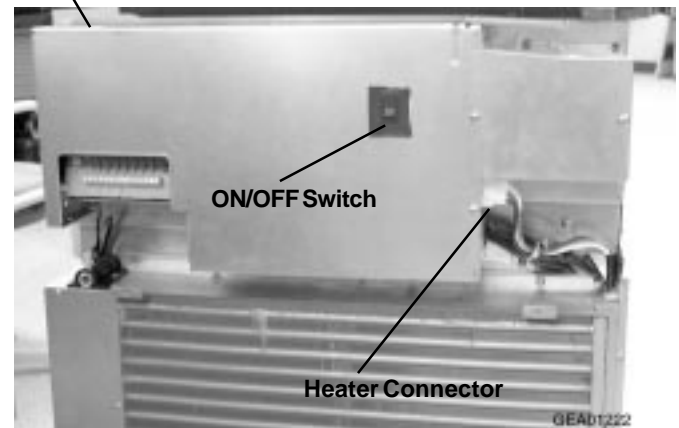

Driver Board

To access the driver board:

Remove the electronics cover (see Main Board section).

Fuse

A 4-amp fuse is located on the driver board, and is common to the transformer circuit. If this fuse blows (open), all relays and the remote thermostat will not function.

Sub Board

To access the sub board:

Remove the electronics cover (see Main Board section).

Main Board Sub Board Driver Board

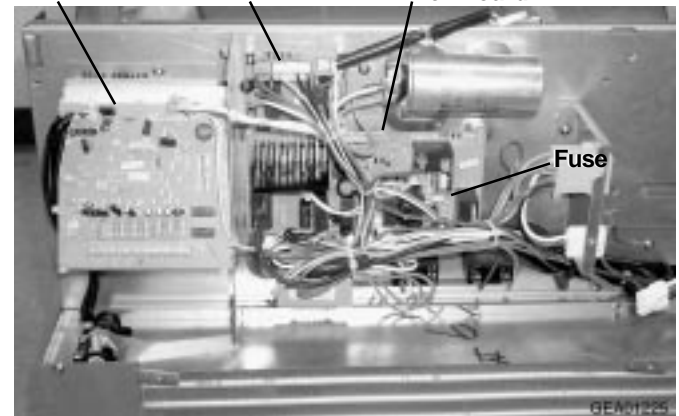

Compressor and Capacitor

The Zonline compressor is a rotary type that operates on 265/230/208 VAC. After the compressor has cycled off, it will not attempt to restart for 3 minutes +/- 10 seconds, regardless of the state of the thermostat. This will allow internal pressure to equalize and prevent the compressor from stalling by trying to start against high pressure in the sealed system.

Current flow into the compressor is monitored by the main board to determine if the compressor is running or locked. If the run signal is sent and a locked condition is detected for 4 seconds, the run signal will stop and a 3-minute count will begin. After the 3-minute count, the run signal is sent again. If the compressor starts, the count is reset and the unit functions normally. If the compressor does not start after 4 consecutive attempts, the control will determine that a compressor failure has occurred and a beeping alarm will sound. The alarm will continue until the compressor failure condition is reset by turning the unit off at the ON/OFF switch or by removing power to the unit.

The compressor overload is internal to the compressor for 18000 BTU models and is located under the relay/overload cover for 9000 and 12000 BTU models. Should the overload trip (open) it will open the common line to the compressor, stopping compressor operation.

A copper process tube is provided for access to the low-pressure side of the refrigeration system.

The compressor capacitor is located under the electronics cover, above the driver board.

Compressor

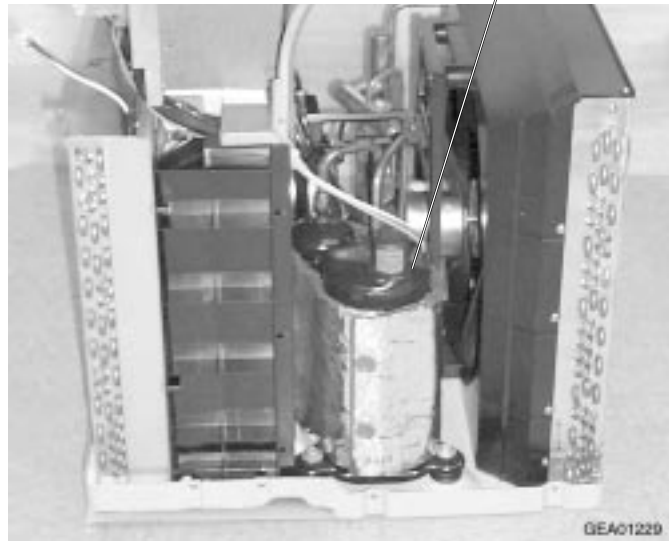

Compressor Capacitor

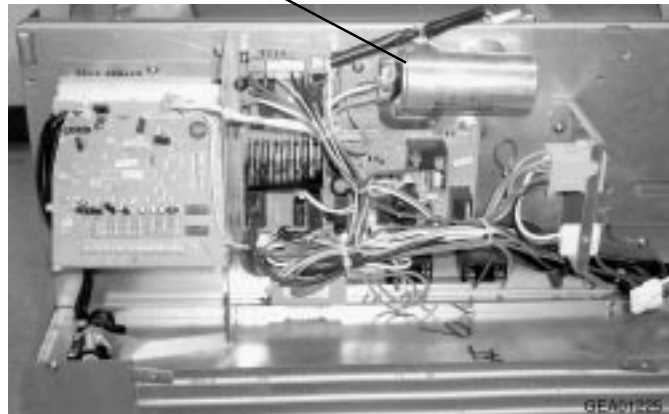

Filter/Dryer

The filter/dryer for heat pump models is located in the horizontal section of the discharge tube between the compressor and reversing valve.

The filter dryer for electric resistance heat models is located in the liquid tube between the condenser and the capillaries.

Compressor Resistance Values

Compressor Size	Winding C to R	Winding C to S
9000 BTU 230/208 VAC	3.4 Ω	5.8 Ω
12000 BTU 230/208 VAC	2.3 Ω	2.1 Ω
18000 BTU 230/208 VAC	2 Ω	2.2 Ω

Note: On 18000 BTU models, overload protection is internal to the compressor.

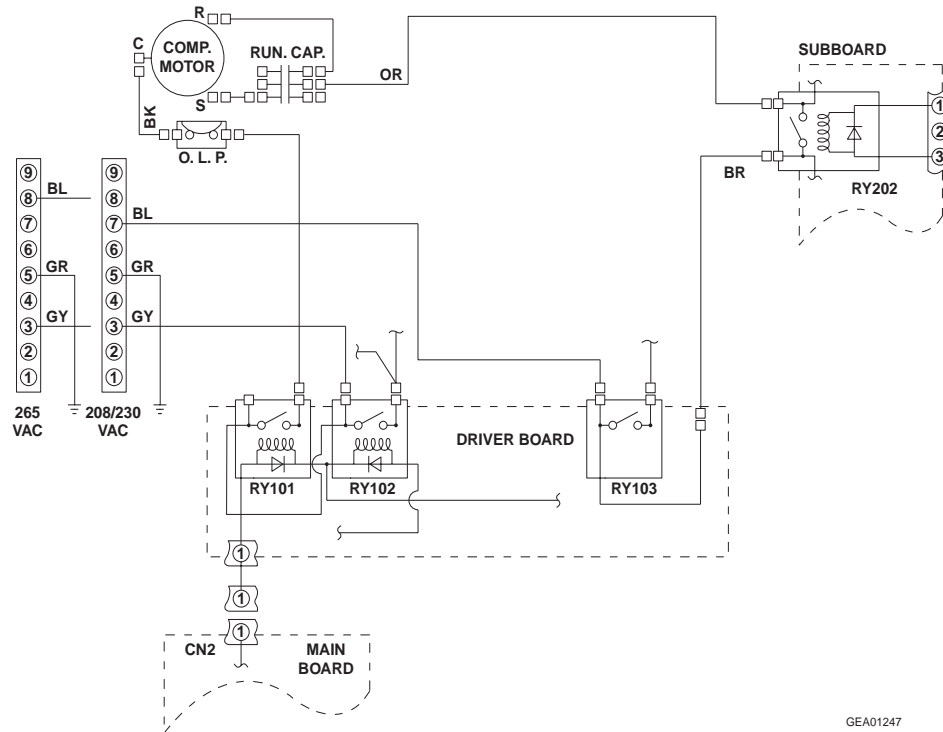

GEA01247

Compressor Troubleshooting

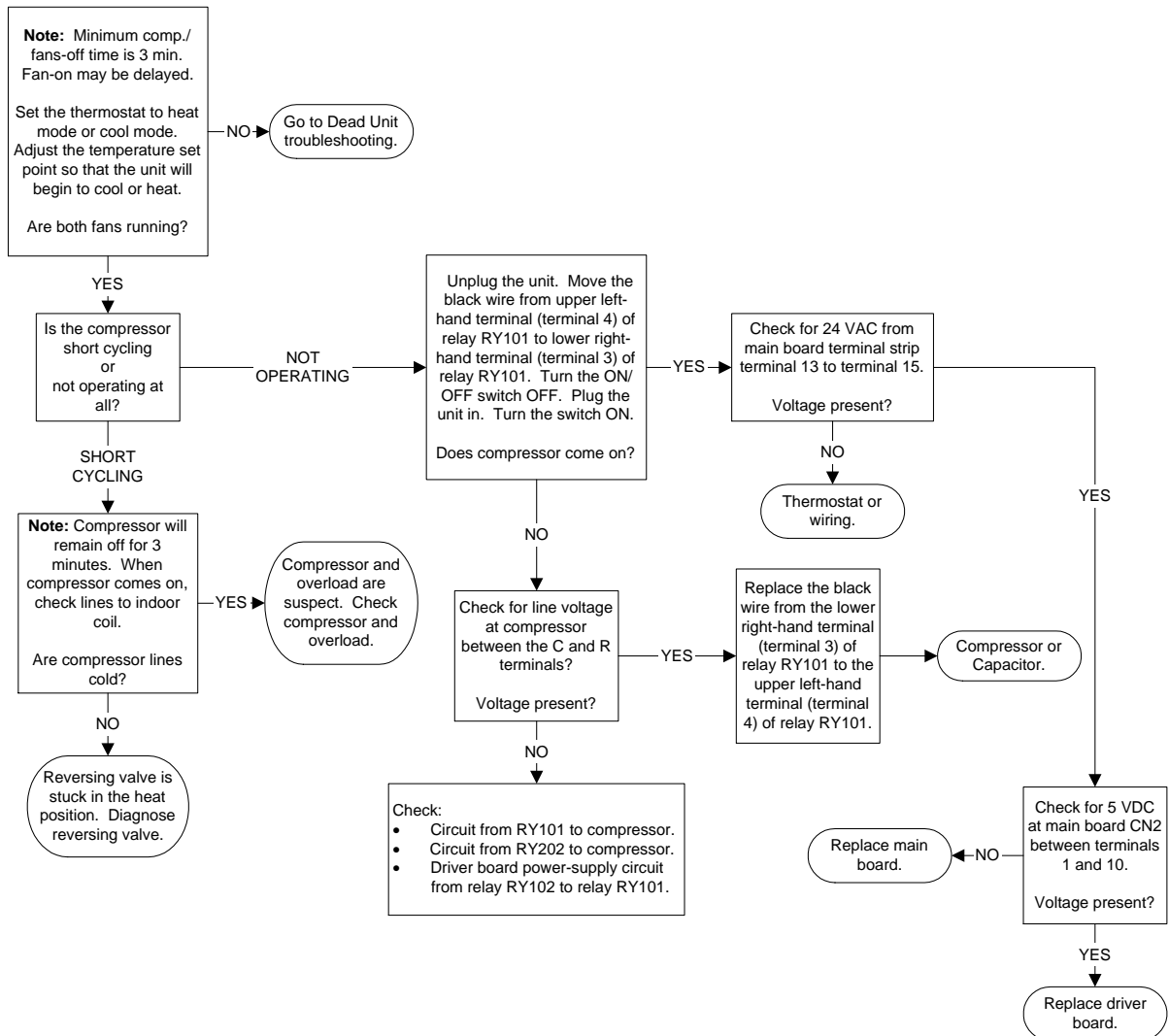

Resistance Heaters

The heaters consist of three 265 VAC or 230/208 VAC resistance heating coils fastened together in a single assembly. The heaters are located behind the indoor coil and are protected against overheating by 2 thermal protectors. An L185-30 thermal protector is used as a temperature regulator. A one-shot L248 thermal protector is used as a backup in case the temperature regulating thermal protector fails (stuck closed).

Heat Pump models will utilize electric resistance heat upon initial heat mode startup or when a power outage has occurred with the unit in heat mode. The electric heaters will be energized until the room temperature reaches the thermostat setting. Once the thermostat temperature setting is attained, the unit will cycle off and automatically switch over to heat pump operation. The heat pump will provide all heating requirements for subsequent cycles unless one of the following conditions occur:

- The dip switch has been placed in the I2R (ALLELECTRIC HEAT) position. When the dip switch is placed in the up position, heat pump operation will be locked out. Only electric resistance heat will be available.
- A temperature differential of approximately 2 °F (temperature differential varies by thermostat manufacturer) is detected between the thermostat set point and the room air temperature. If a differential of approximately 2 °F is detected, due to thermostat adjustment or falling room air temperature, the electric heaters will be energized (heat pump off) until the thermostat is satisfied. Once the thermostat has been satisfied, the unit will automatically revert back to heat pump operation for subsequent cycles.
- The outdoor temperature falls below 25 °F. If the outdoor temperature falls below 25 °F, the unit will automatically switch from heat pump operation to resistance heat operation. A 7 °F hysteresis loop will be in effect; therefore, the unit will operate in resistance heat mode until an outdoor temperature of 32 °F or higher is detected.

Electric resistance heat and heat pump operation will never occur at the same time.

Models without heat pump feature will meet heating requirements by use of electric resistance heating coils.

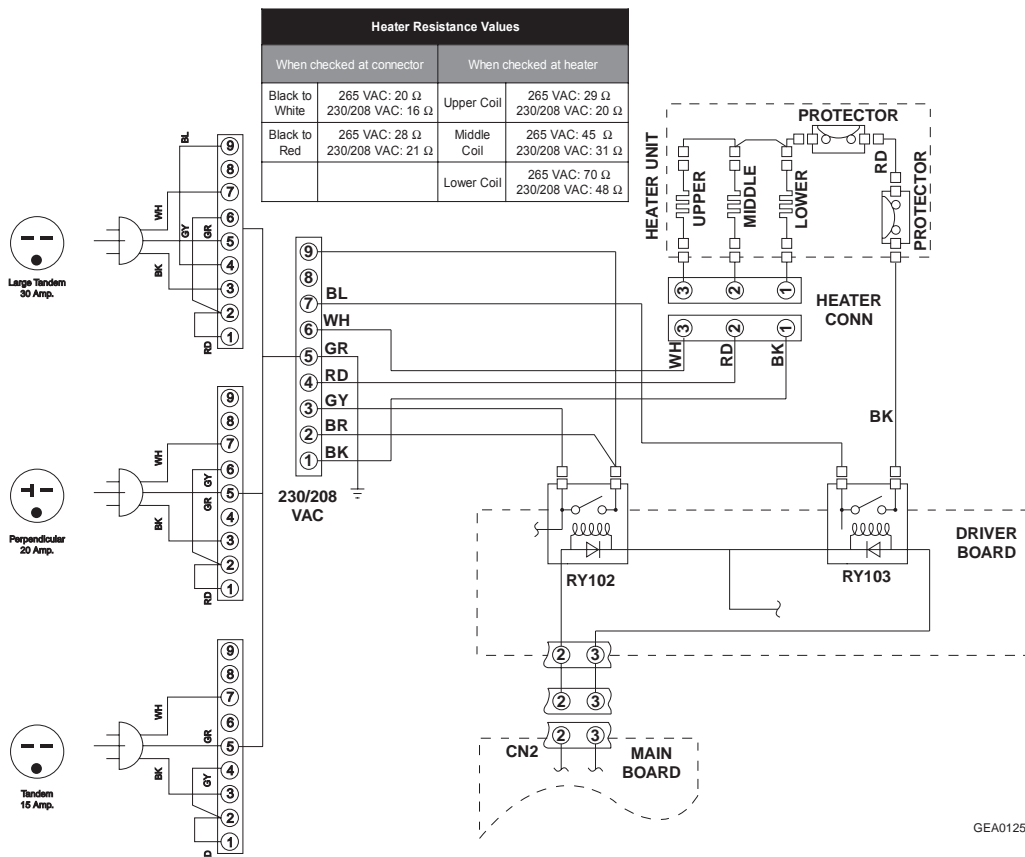

GEA01253

Resistance Heater Troubleshooting

Note: Normal heat is provided by heat pump operation when outdoor temperature is above 25 °F. The number of heaters that operate is dependant on the Power Supply Kit used.

- Tandem - 1 heater
- Perpendicular - 2 heaters
- Large Tandem - 3 heaters

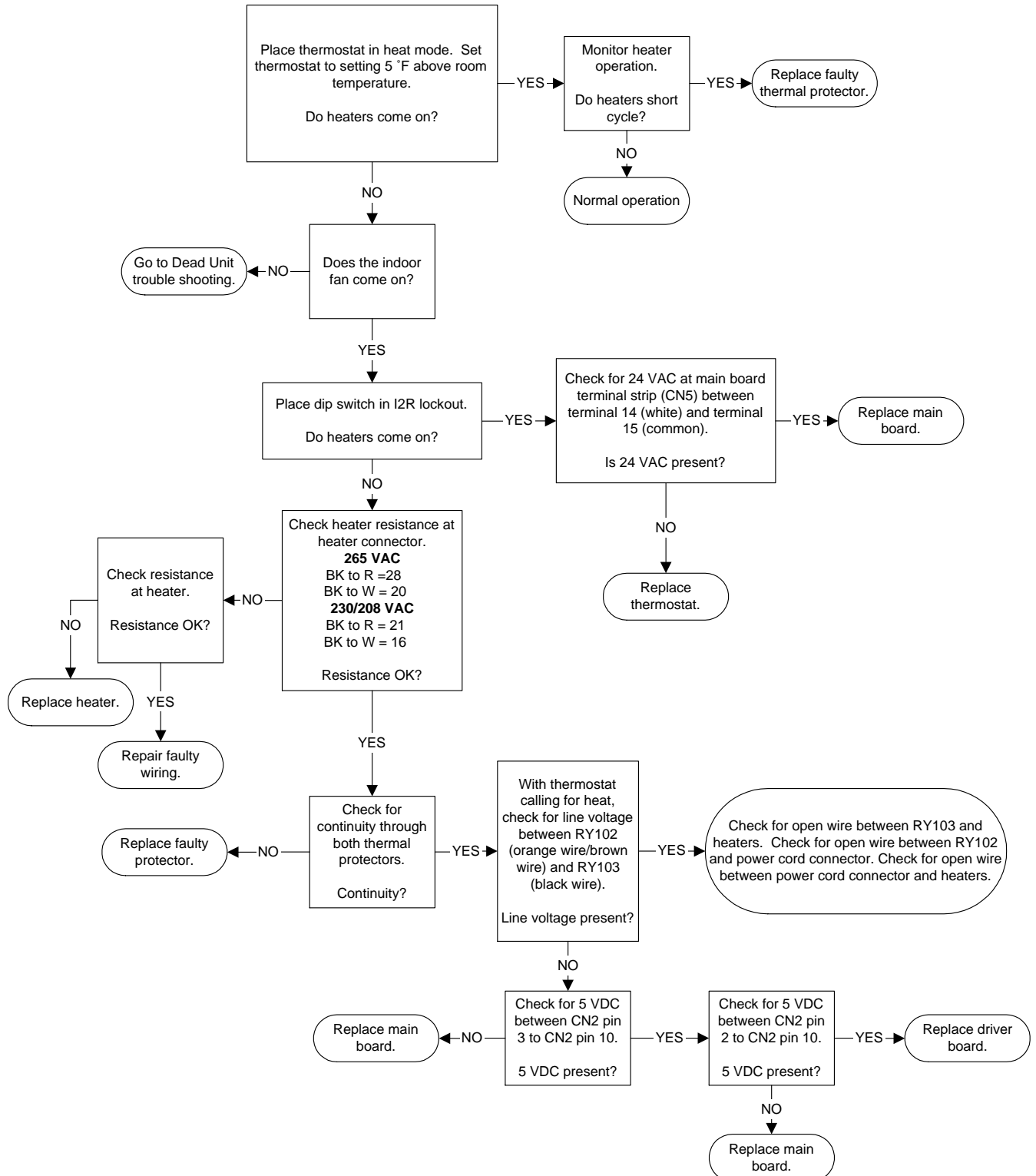

To remove the resistance heaters:

1. Remove the front panel and slide the chassis forward approximately 5 in. (see Slide-Out Chassis chapter).
2. Remove electronics cover (see Main Board chapter).
3. Remove the left and right corner sheet metal panels fastened to the sides of the indoor coil.
4. Remove 3 screws fastening the ventilation control to the indoor coil top panel.
5. Remove 4 screws and the indoor coil top panel.
6. Carefully position the indoor coil to allow access to 4 heater assembly mounting screws.
7. Remove 4 screws and the heater.
8. Tag and disconnect wires.
9. Slide the heater out of the right side of the unit.

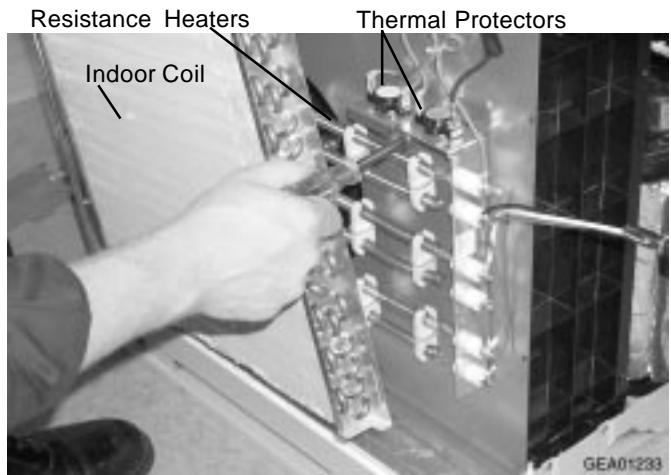
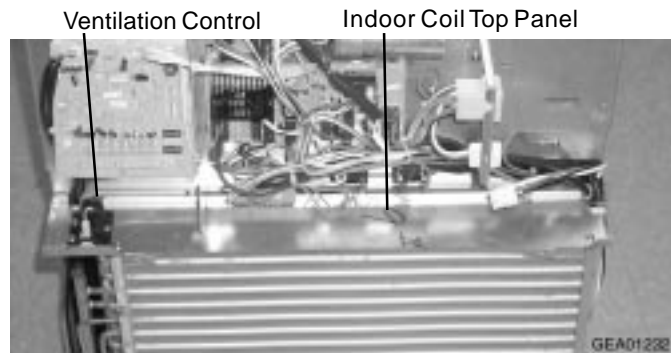
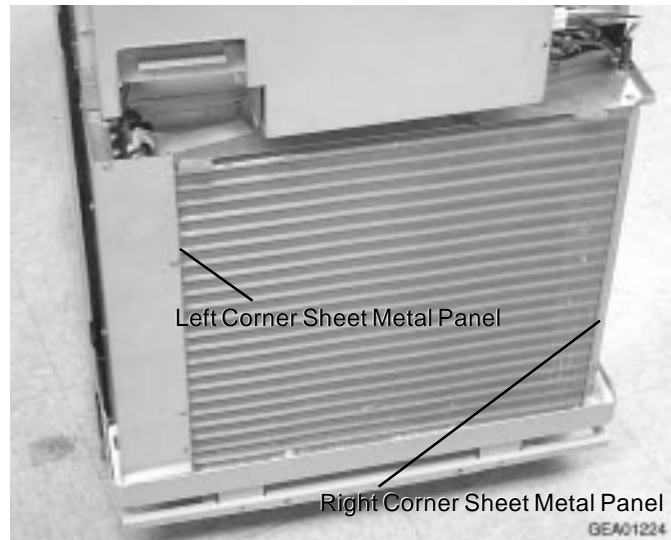

To Test Heaters and Thermal Protectors:

Disconnect the heater connector. Measure the resistance of each coil using the following resistance values.

Heater Resistance Values			
When checked at connector		When checked at heater	
Black to White	265 VAC: 20 Ω 230/208 VAC: 16 Ω	Upper Coil	265 VAC: 29 Ω 230/208 VAC: 20 Ω
Black to Red	265 VAC: 28 Ω 230/208 VAC: 21 Ω	Middle Coil	265 VAC: 45 Ω 230/208 VAC: 31 Ω
		Lower Coil	265 VAC: 70 Ω 230/208 VAC: 48 Ω

Check the thermal protectors for continuity between heater connector terminal 1 (black wire) and the black wire to relay RY103.

Note: A continuity reading on a thermal protector indicates that the protector is closed at the time of the check only. A faulty thermal protector may open prematurely, resulting in insufficient heating.

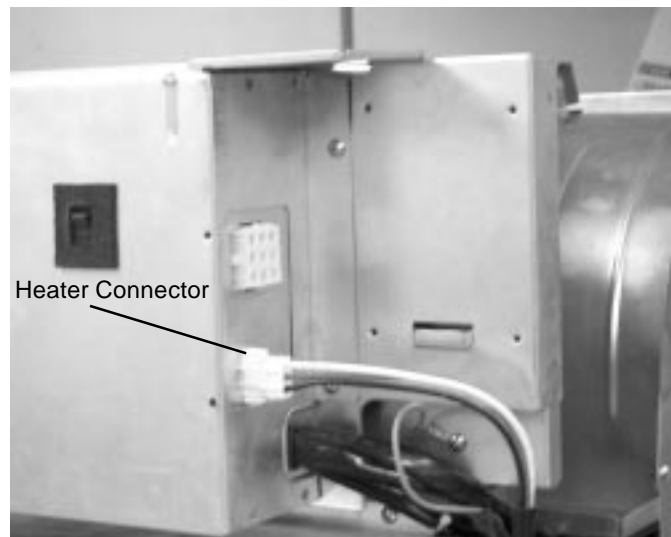

Indoor Fan and Capacitor

The indoor fan is a 265/230/208 VAC, permanently lubricated motor. Indoor fan speed is selected in the following manner:

When the green thermostat wire is connected to the high-speed fan (**GH**) terminal:

DUCT SWITCH UP = HIGH FAN SPEED

DUCT SWITCH DOWN = MEDIUM FAN SPEED

When the green thermostat wire is connected to the low-speed fan (**GL**) terminal:

DUCT SWITCH UP = MEDIUM FAN SPEED

DUCT SWITCH DOWN = LOW FAN SPEED

The indoor fan and outdoor fan will operate simultaneously under normal operating conditions. To energize the fans, press the FAN button on the thermostat. When fan ON mode is selected, the fans will run continuously, independent of the compressor or heaters. Selecting AUTO on the thermostat will cause the fans to automatically cycle on and off with the compressor or heaters. The fans will always run when the compressor or heaters are operating. They will start before compressor or heater operation, and will stop after compressor or heater operation has ended. The fans can also be set to run continually, regardless of thermostat setting, by placing the CONST FAN dip switch in the (UP) position (see Dip Switches section of the Features and Operation chapter).

The indoor fan capacitor is located under the electronics cover and below the driver board.

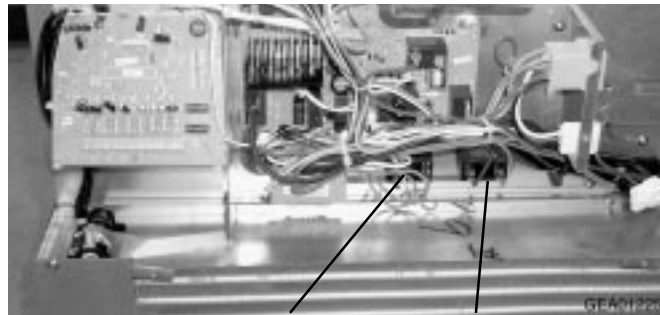

Indoor Fan Capacitor Outdoor Fan Capacitor

To remove the outdoor fan:

1. Remove the unit from the cabinet (see Slide-Out Chassis chapter).
2. Remove the left and right divider assemblies.
3. Remove the electronics cover (see Main Board chapter).
4. Remove the resistance heaters (see Resistance Heaters chapter).
5. Remove 1 screw and slide the metal panel from in back of the indoor coil out the right side of the unit.
6. Loosen the Phillips head setscrew securing the blower wheel.

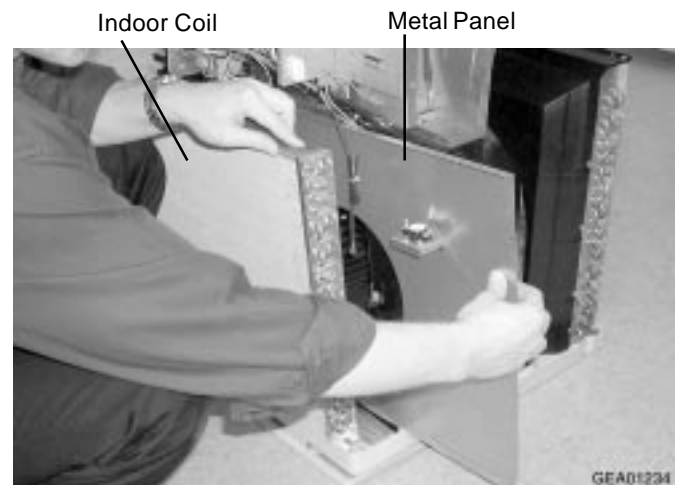

Note: Position blower wheel setscrew on the flat side of the motor shaft when reassembling.

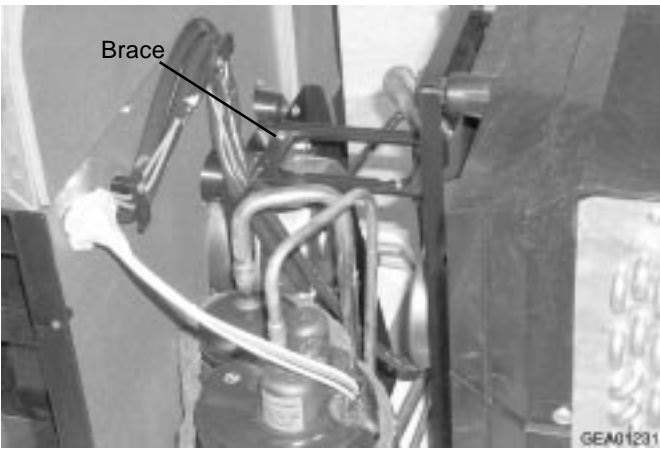

7. Remove 3 screws and the brace above the indoor fan motor.
8. Disconnect the indoor fan wiring connector (CN101) at the driver board.

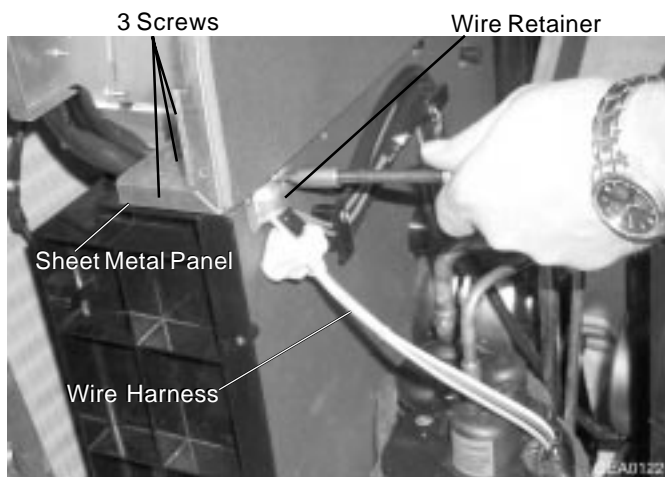

9. Disconnect CN201 from sub board.
10. Remove 3 screws from the sheet metal panel on top of the fan shroud above the wire retainer.
11. Remove the metal wire retainer and the wire harness.

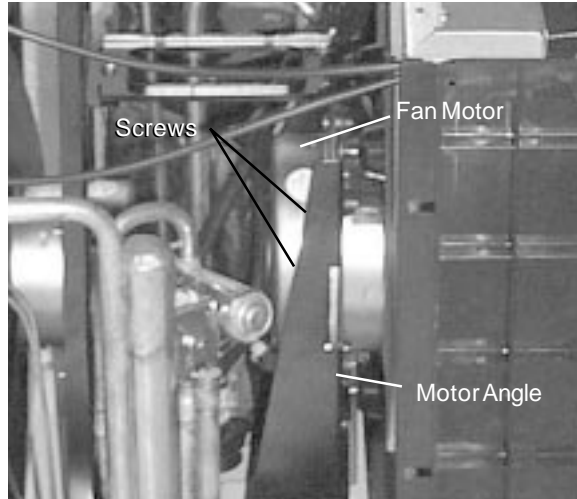

Note: Collars are placed on the 4 fan mounting screws. Use care not to lose collars.

12. Remove 4 screws, the fan motor, and the motor rubber from the indoor fan motor angle.

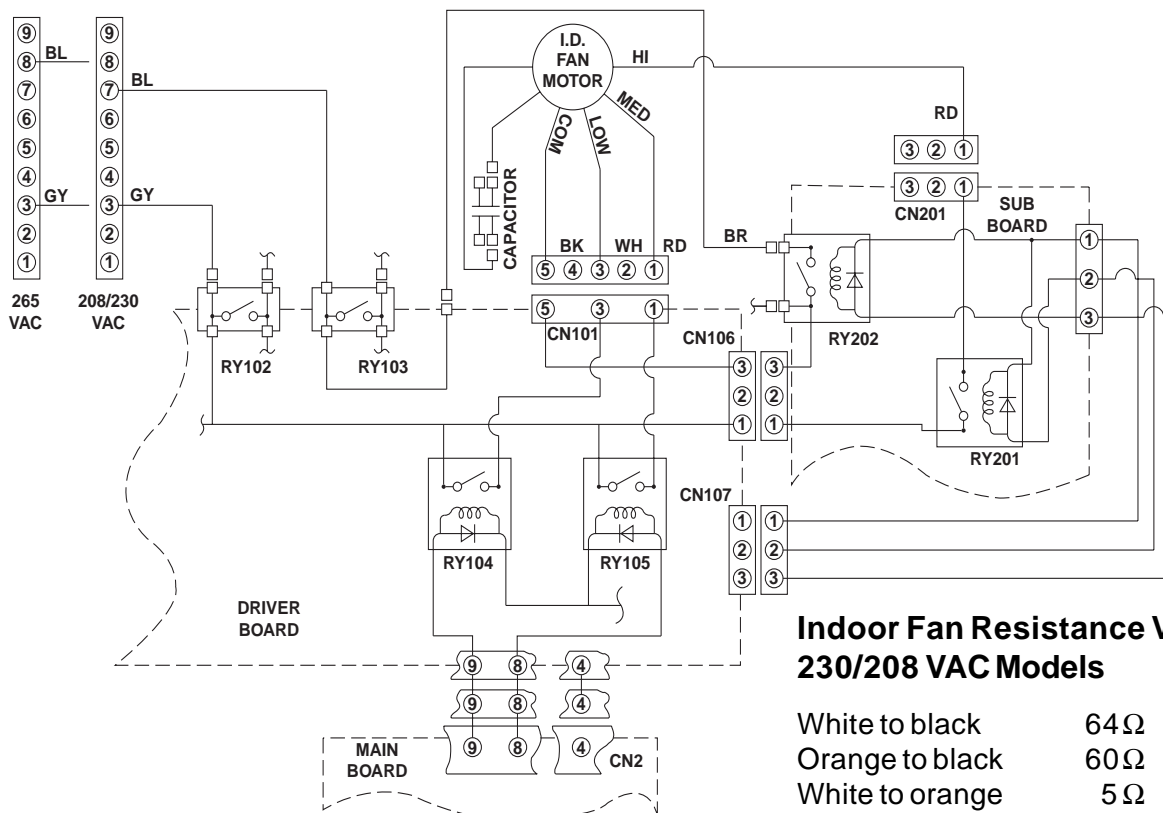

**Indoor Fan Resistance Values
230/208 VAC Models**

White to black	64 Ω
Orange to black	60 Ω
White to orange	5 Ω

GEA01245

Indoor Fan

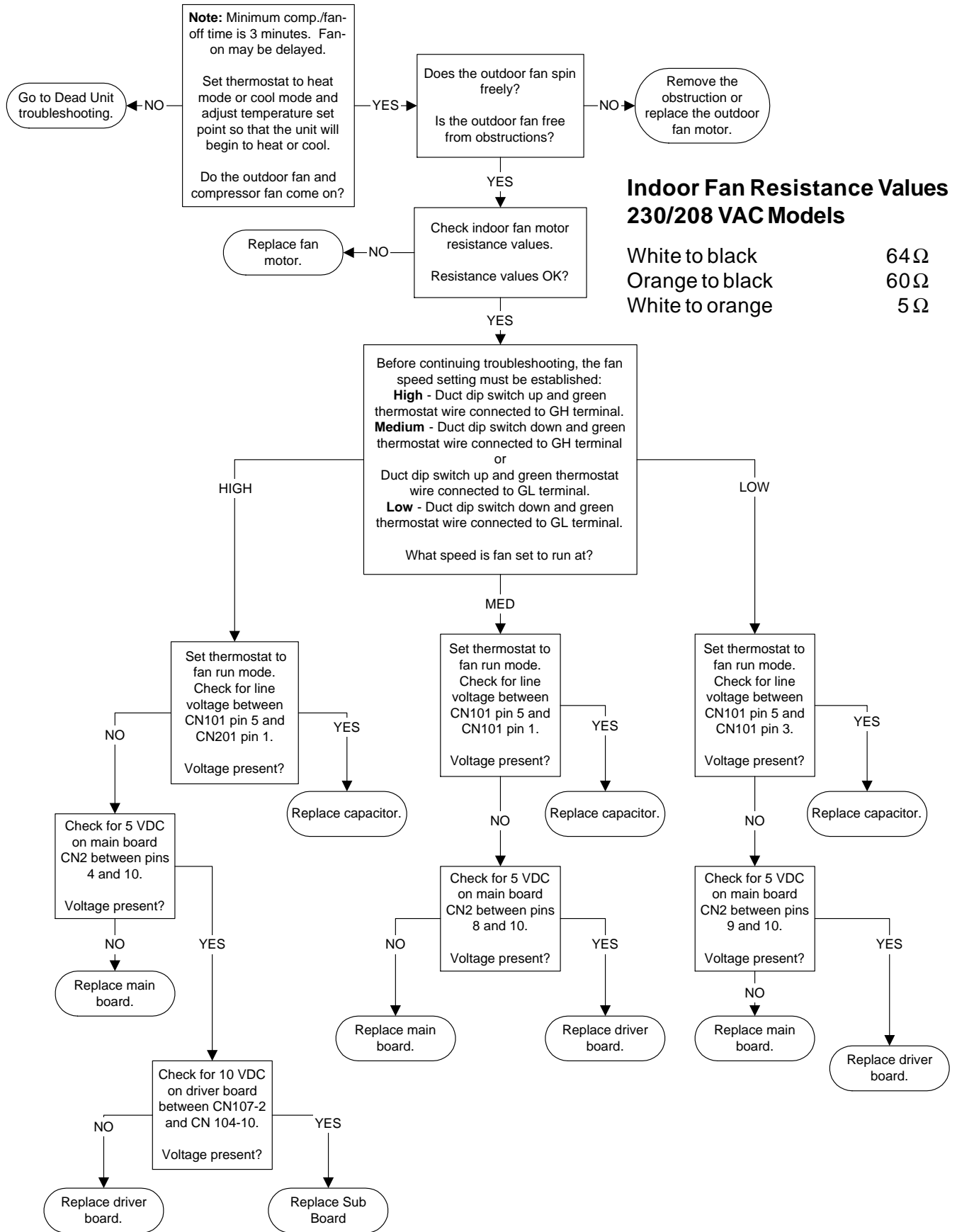

Outdoor Fan and Capacitor

The outdoor fan is a single-speed, 265/230/208 VAC, permanently lubricated motor.

The indoor fan and outdoor fan will operate simultaneously under normal operating conditions. However, if the heat pump is operated when high outdoor temperatures are present, the indoor coil may overheat. Should the indoor coil temperature reach 131 °F, the main board will shut the outdoor fan off. A 5 °F hysteresis loop will restore outdoor fan operation when the indoor coil temperature lowers to 126 °F.

To energize the fans, press the FAN button on the thermostat. When fan ON mode is selected, the fans will run continuously, independent of the compressor or heaters. Selecting AUTO on the thermostat will cause the fans to automatically cycle on and off with the compressor or heaters. The fans will always run when the compressor or heaters are operating. They will start before compressor or heater operation, and will stop after compressor or heater operation has ended. The fans can also be set to run continually, regardless of thermostat setting, by placing the CONST FAN dip switch in the UP position (see Dip Switches section of the Features and Operation chapter).

The outdoor fan capacitor is located under the electronics cover and below the driver board.

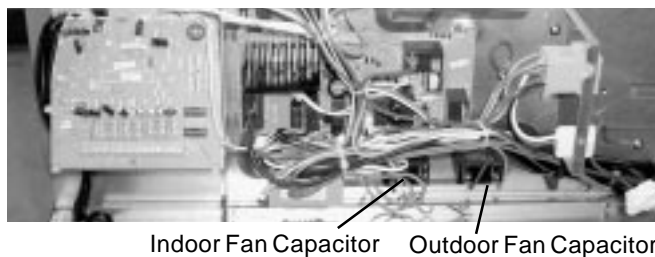

To remove the outdoor fan:

1. Remove the unit from the cabinet (see Slide-Out Chassis chapter).
2. Remove the left and right divider assemblies (outer sheet metal panels).
3. Remove 8 screws from the fan shroud.
4. Remove 3 screws and the brace above the outdoor fan motor.
5. Disconnect the outdoor fan wiring connector at the drive board.
6. Remove 2 screws fastening the bottom of the outdoor fan motor angle to the base plate.
7. Lift the fan shroud, motor angle, and fan motor as an assembly and remove them from the right side of the unit.
8. Remove the 8 mm nut fastening the fan blade to the motor shaft.
9. Grasp the fan motor shaft with locking pliers. While holding the shaft, turn the fan blade counterclockwise to unscrew the blade from the shaft.
10. Remove 4 screws, 8 lockwashers, and the fan motor from the fan motor angle.

Note: Lockwashers are placed between the screw head and fan motor, and between the fan motor and the fan motor angle.

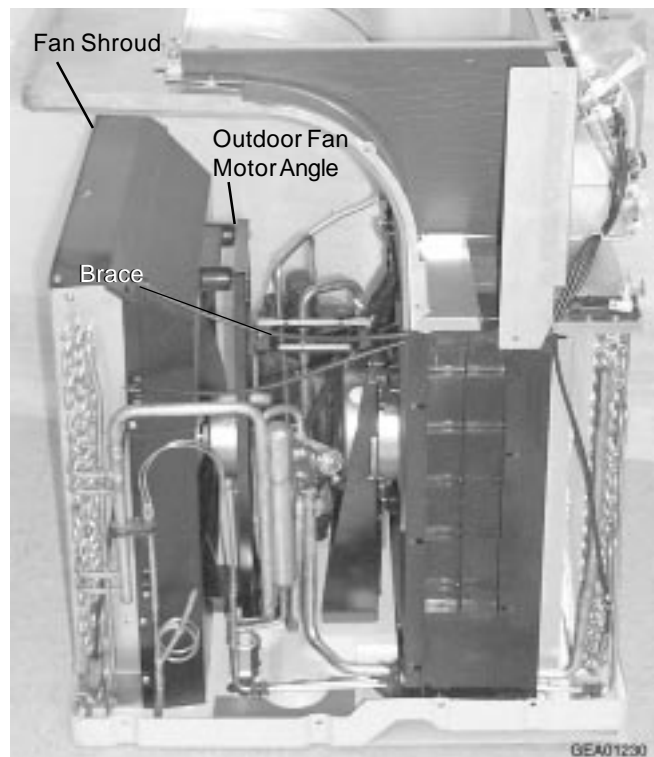

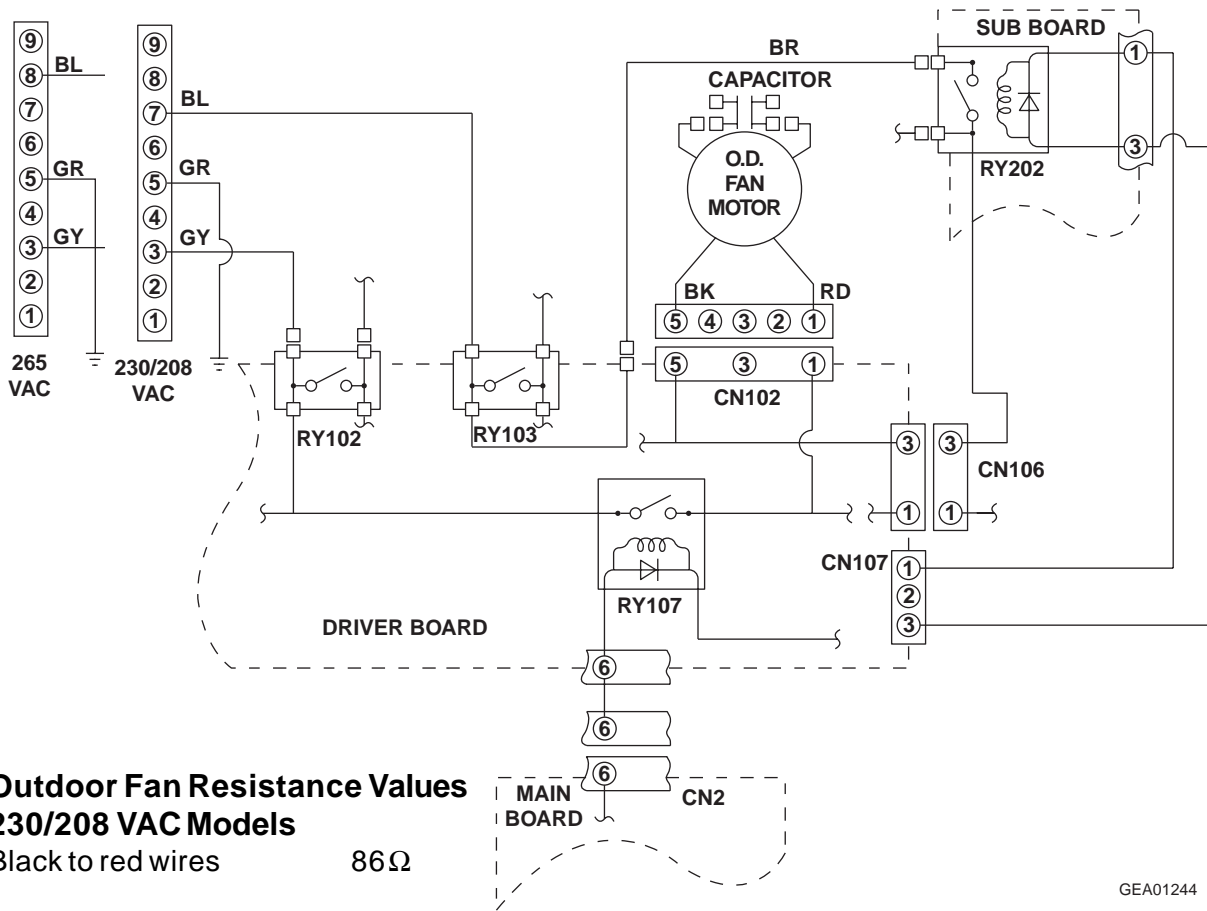

Outdoor Fan Troubleshooting

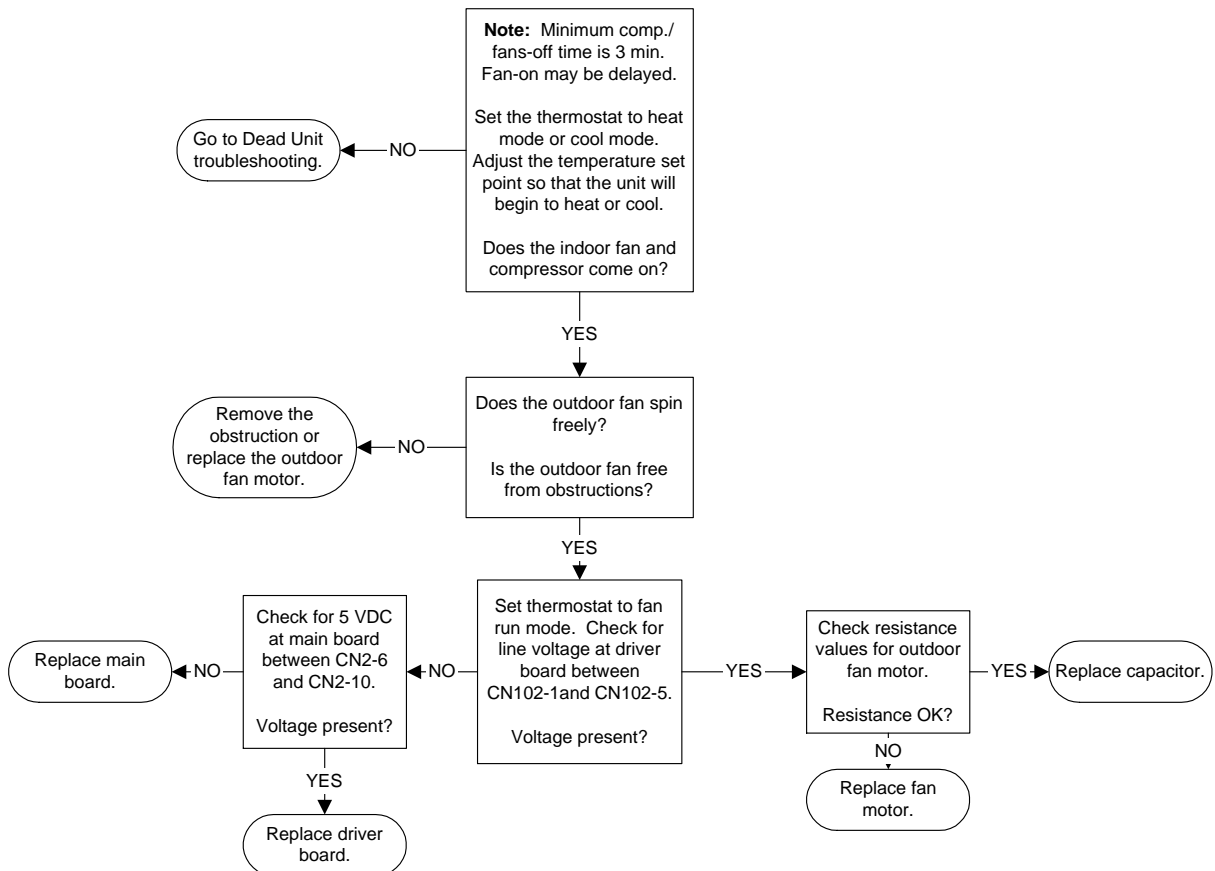

Reversing Valve

The reversing valve operates on 265/230/208 VAC and is used to switch the direction of refrigerant flow. The reversing valve controls the direction of the refrigerant flow. When the reversing valve solenoid is energized, it will close the reversing valve and the unit will operate as an air conditioner. When the solenoid is de-energized, the reversing valve will open and the unit will function as a heat pump.

To confirm that the reversing valve and reversing valve solenoid are functioning properly, the main board continually monitors the indoor coil thermistor and outdoor coil thermistor. Should the system operate in the reverse of the selected mode due to a reversing valve or reversing valve solenoid malfunction, the board will detect improper thermistor readings, determine that the unit is not operating properly, and terminate compressor operation.

Note: Some thermostats can be programmed to energize the reversing valve in heat mode or cool mode. If the thermostat is not programmed correctly, the unit will heat when the thermostat is set to cool and will cool when the thermostat is set to heat. Refer to the instructions provided with the thermostat for thermostat programming procedures. Also refer to the Remote Thermostat Control section of the Features and Operation chapter for more information.

To remove the reversing valve solenoid:

1. Remove the unit from the cabinet (see Slide-Out Chassis chapter).
2. Remove the electronics cover.
3. Remove the left divider assembly.
4. Disconnect the reversing valve solenoid wiring from the driver board.
5. Remove 1 (7 mm) screw and the reversing valve solenoid.

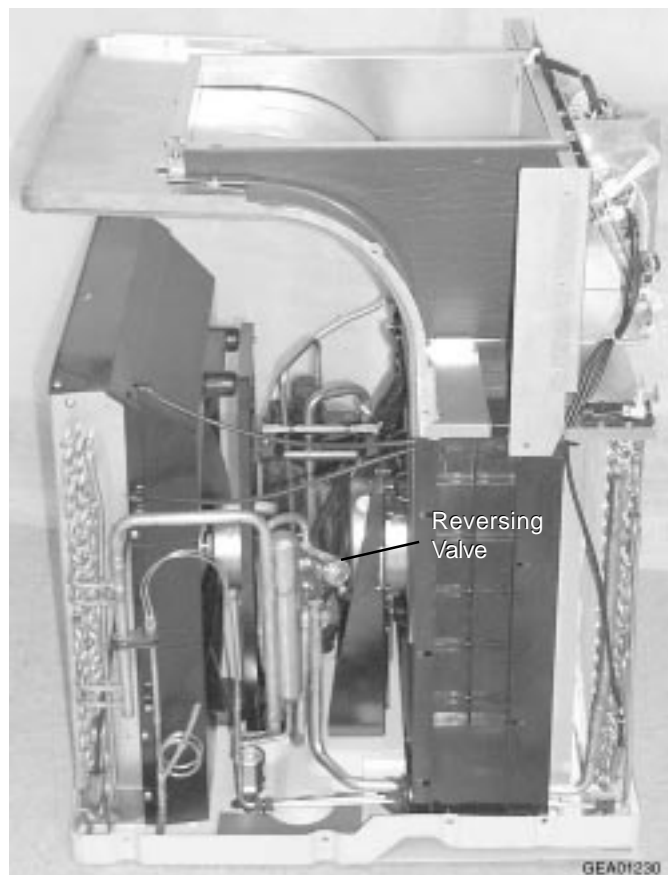

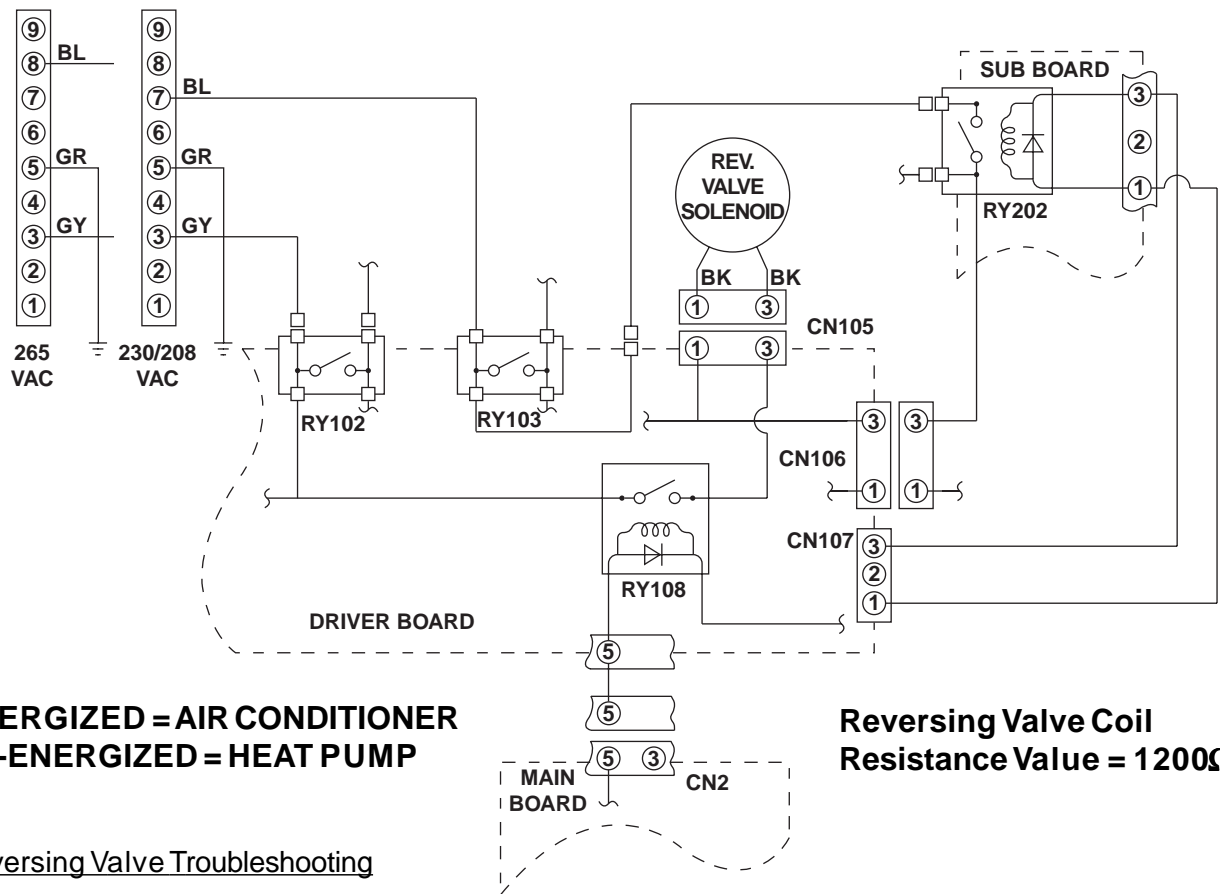

GEA01243

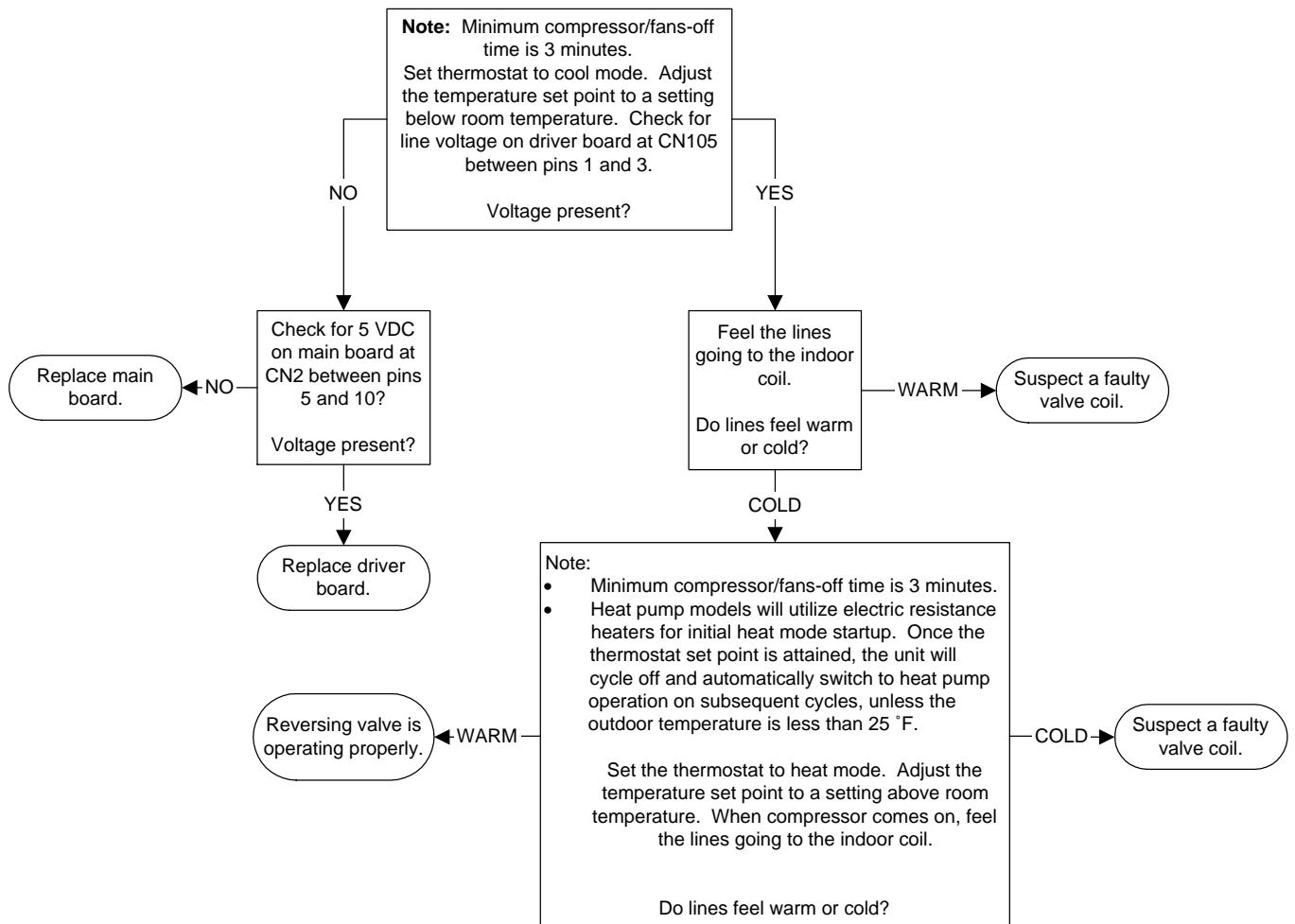

Transformer

The transformer is located under the electronics cover and below the driver board. The transformer provides low voltage power to the main board, driver board and thermostat.

To test the transformer:

Verify line voltage is present at CN204 on sub board. If line voltage is not present, suspect building supply voltage, blown (open) fuse, a faulty sub board or a faulty driver board. If line voltage is present, use the following chart to check the voltage output and resistance values. If values are not correct, replace the transformer.

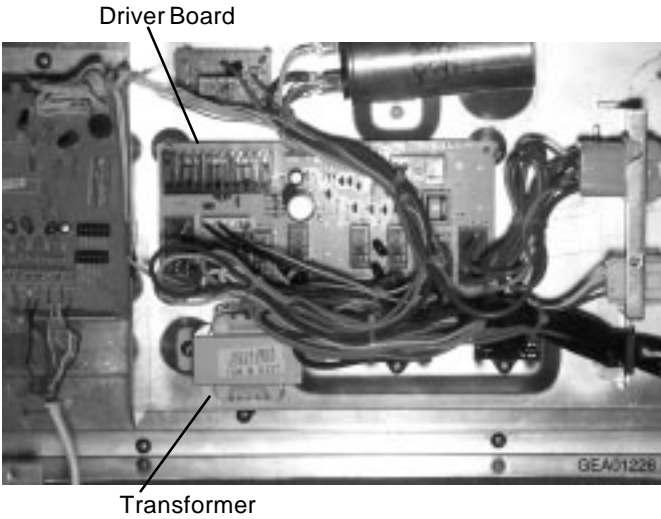

230/208 VAC Transformer Voltage and Resistance Values		
Measure Across	Voltage Output	Resistance
Black to Black	Line in	103 Ω
Yellow to Yellow	12 VAC	1.0 Ω
White to White	24 VAC	3.3 Ω

230/208 VAC version shown

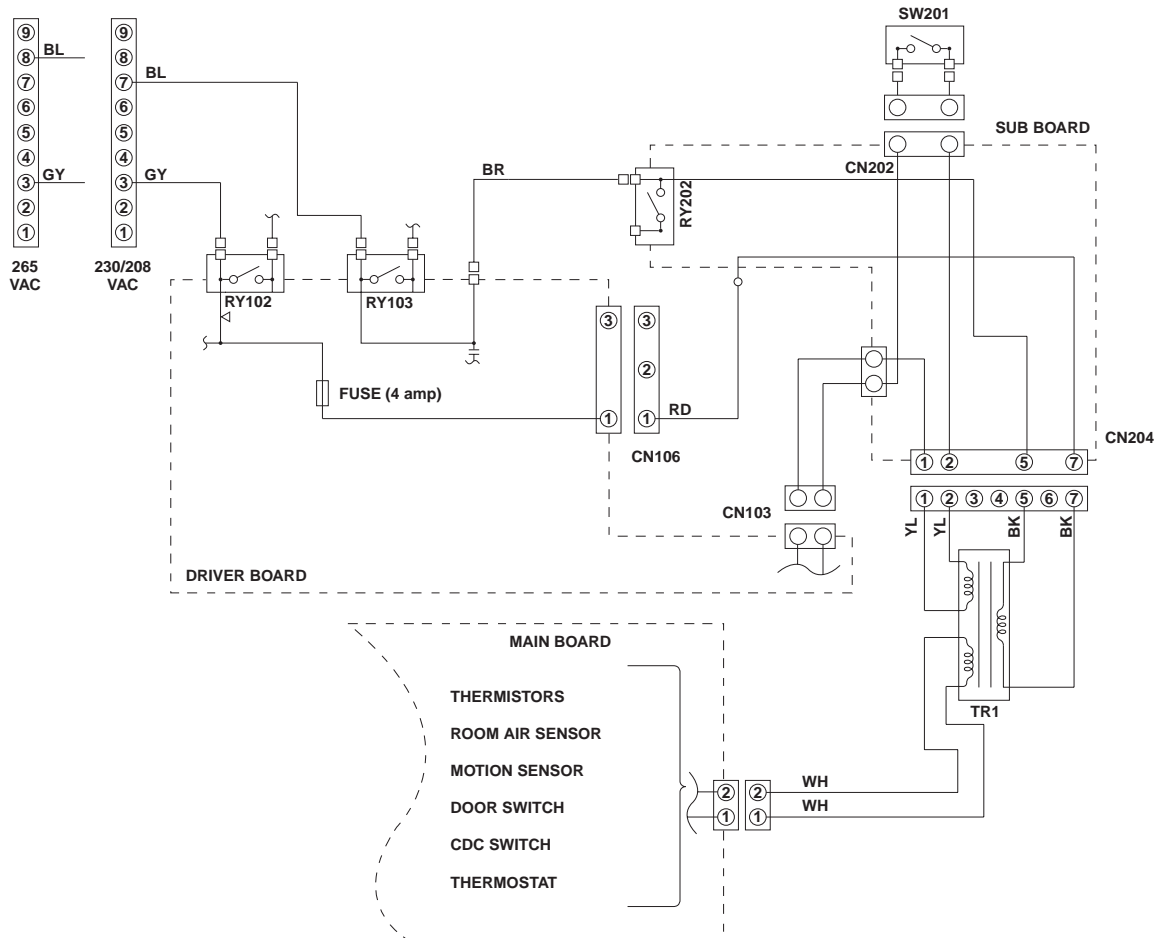

GEA01242

Thermistors

The main control board uses input from 3 thermistors. These thermistors are located on the indoor coil, outdoor coil, and outdoor fan shroud. The main control board monitors the thermistors to determine the temperature in these areas and uses this information to make operating decisions.

For the optional room air sensor (kit), see the Room Air Sensor section in the Features and Operation chapter.

Thermistor Resistance (Ohms)			
Temperature	Indoor Coil	Outdoor Coil	Outdoor Air
10 °F	94900	28030	28030
30 °F	51940	15340	15340
32 °F	49330	14570	14570
50 °F	29960	8850	8850
70 °F	17930	5300	5300
90 °F	10970	3280	3280

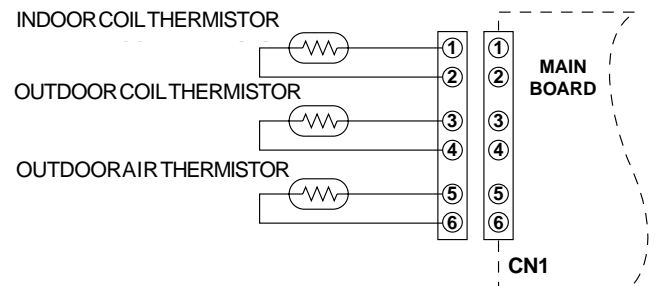

GEA01212

Thermostatic Drain Valve

During the cooling season, the thermostatic drain valve remains closed to allow water to accumulate in the base pan. The water is then picked up by the outdoor fan blade and blown into the condenser, providing more efficient cooling. During heat pump season the thermostatic drain opens to allow water to drain from the base pan prior to freezing. This prevents the outdoor fan blade from scraping against ice that could freeze in the bottom of the base pan.

The thermostatic drain valve is operated by a self-contained thermostat. The thermostat begins to open the drain valve at approximately 58 °F and will be fully open at approximately 45 °F.

To remove the thermostatic drain valve:

1. Remove the unit from the cabinet (see Slide-Out Chassis chapter).
2. Remove the left divider assembly.
3. Remove 2 screws and the thermostatic drain valve.

Dead Unit Troubleshooting

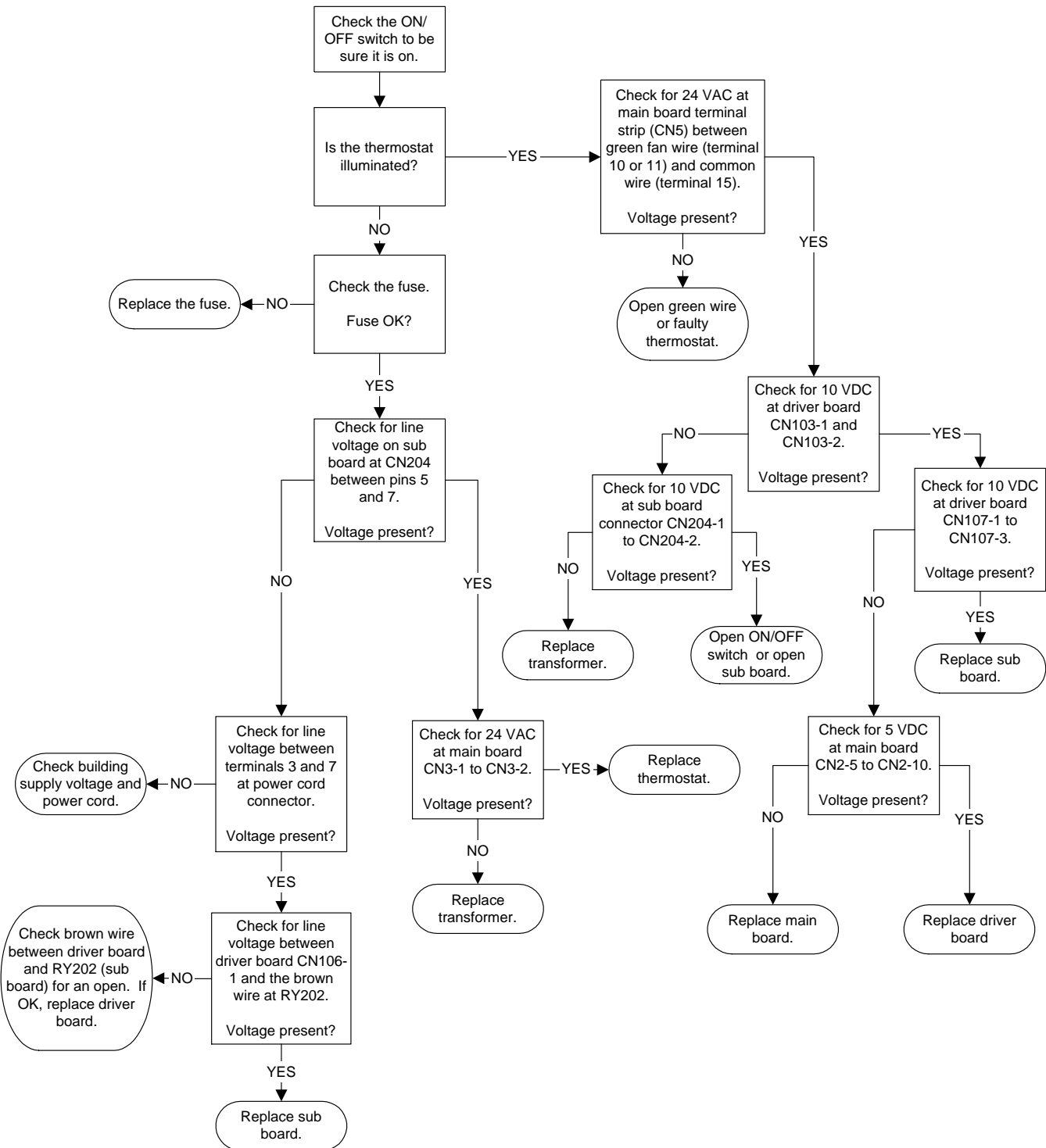

Schematics and Wiring Diagrams

Schematic (Heat Pump Models)

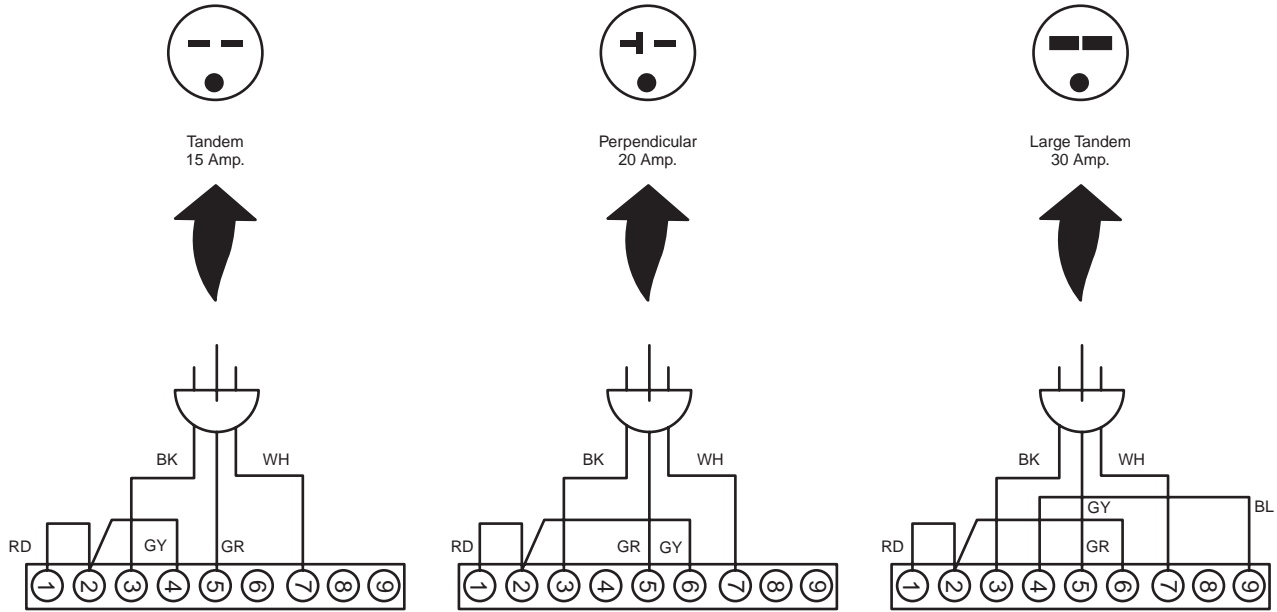

GEA01237

Overload is internal to compressor on 18000 BTU model.

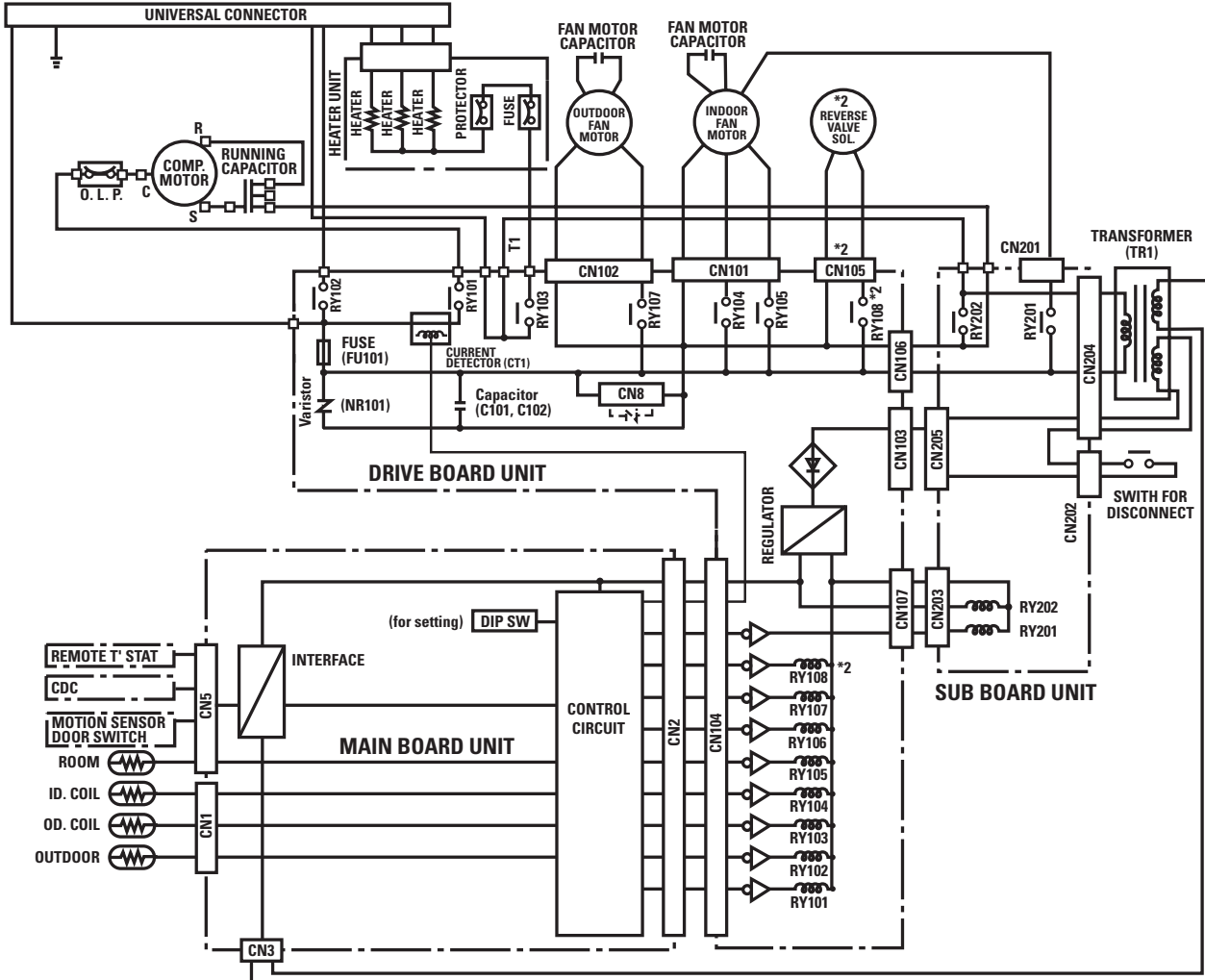

Wiring Diagram (Electric Resistance Heat Models)

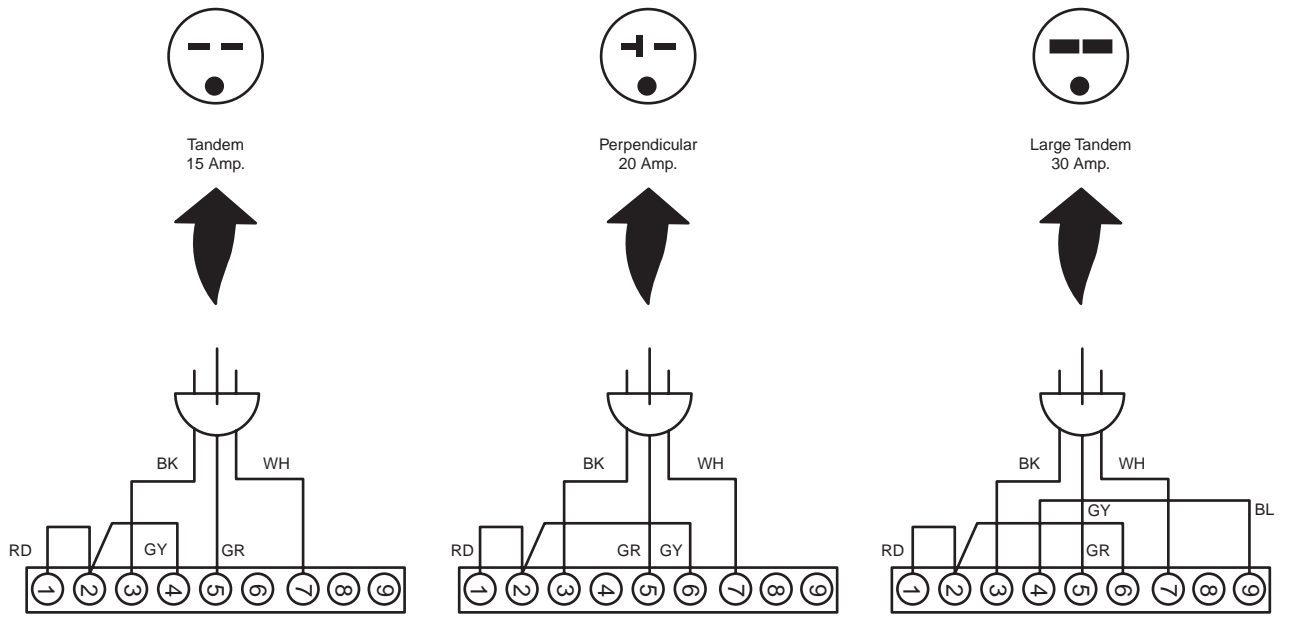

GEA01237

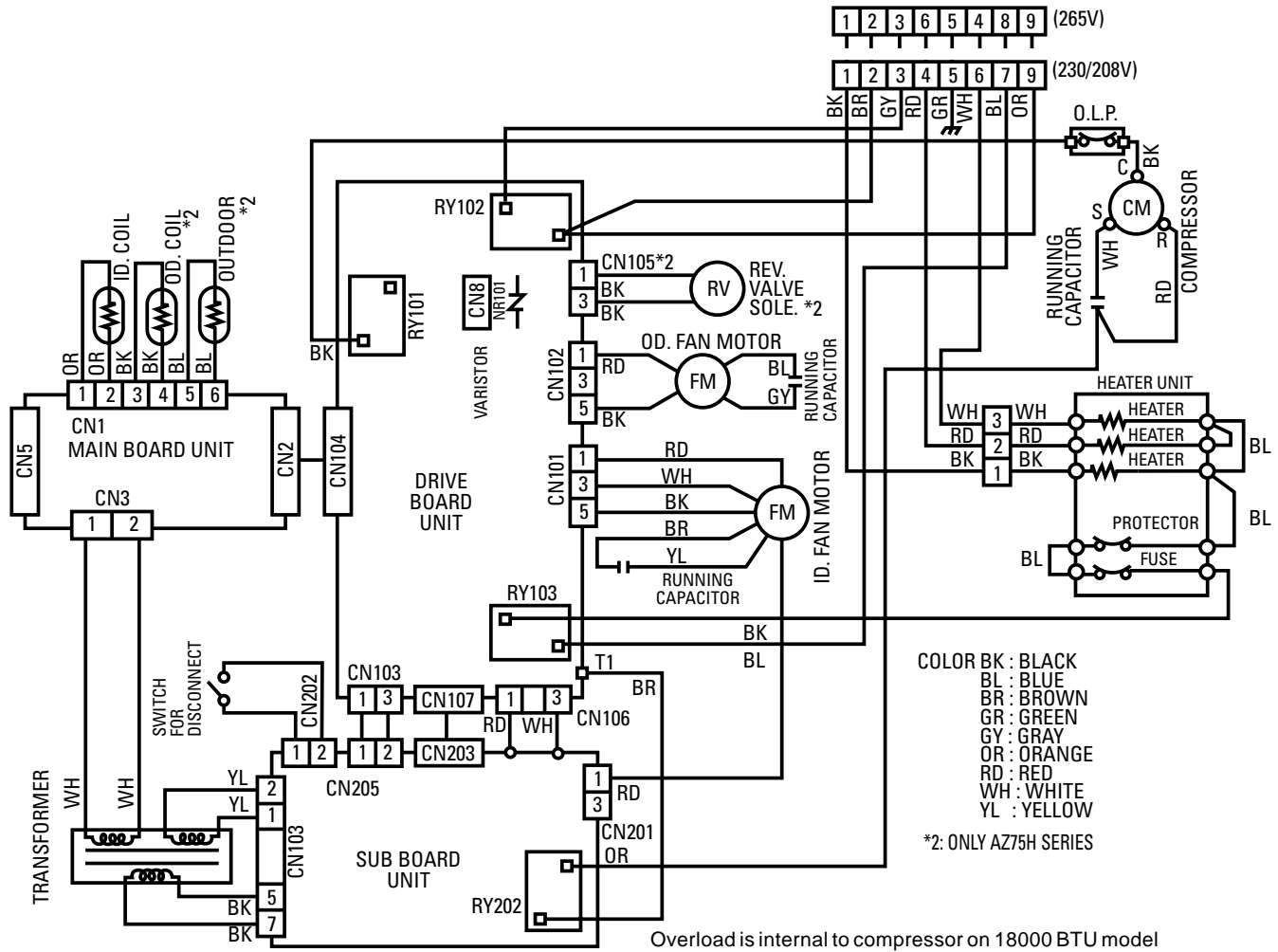

Component Locator Views

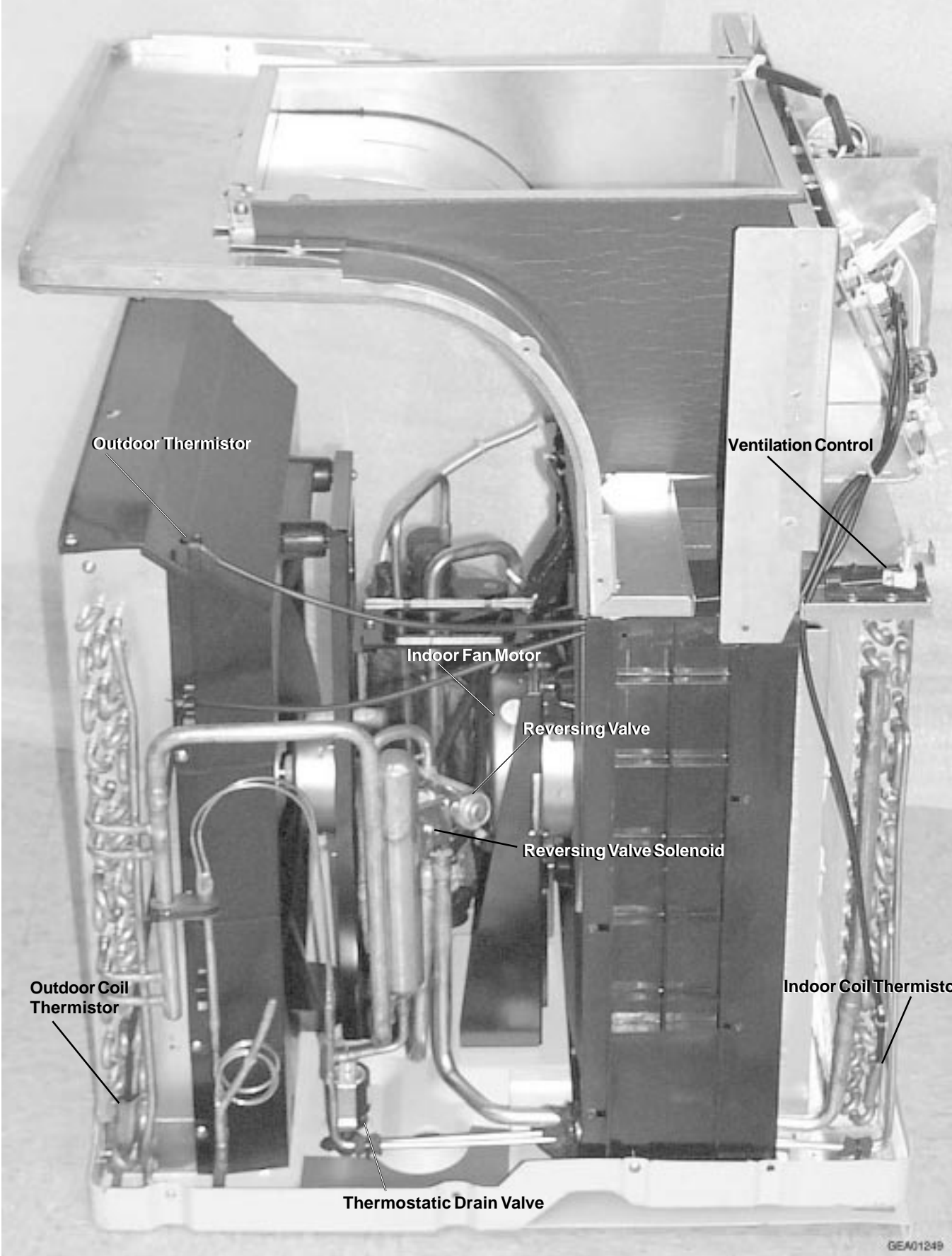

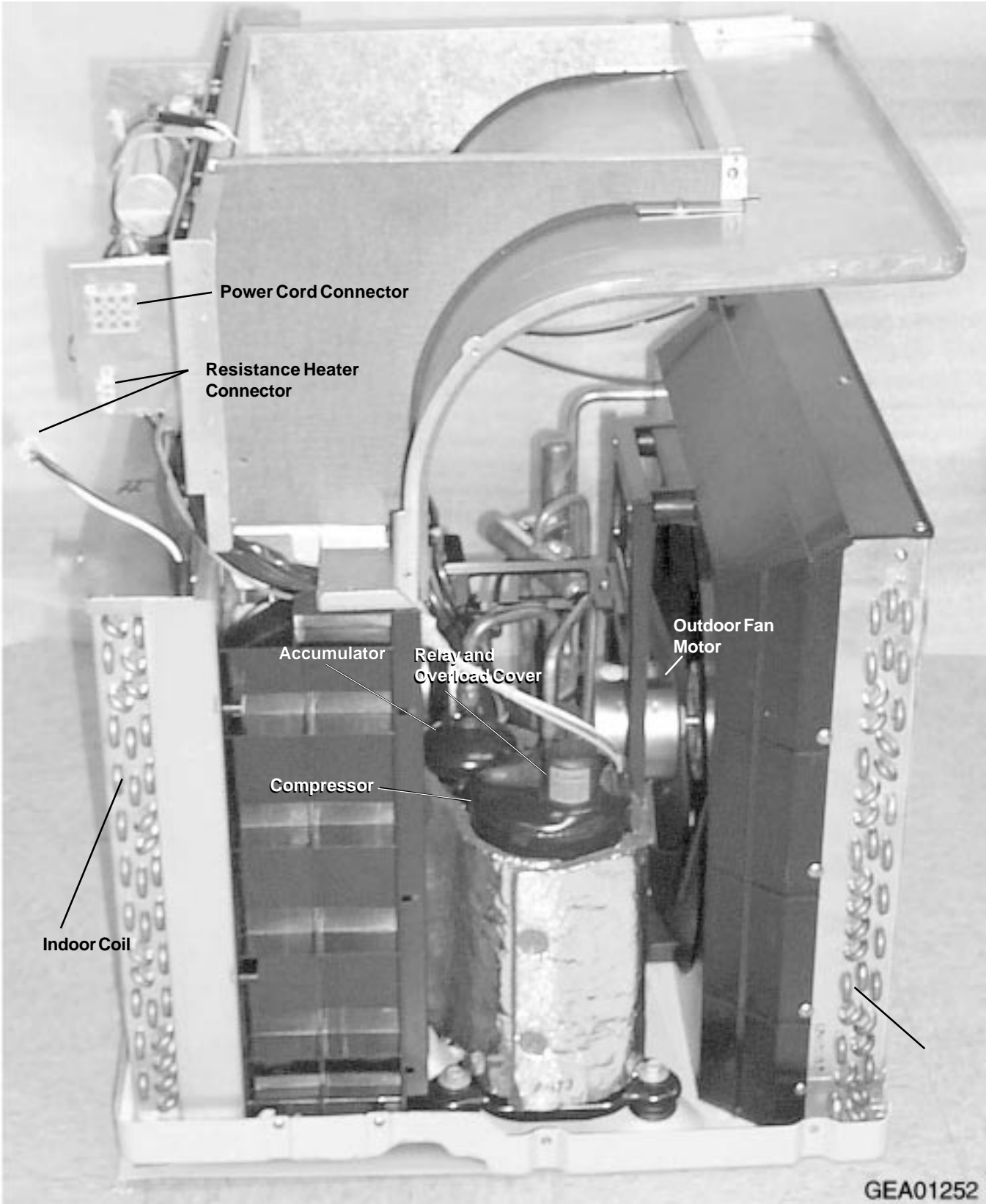

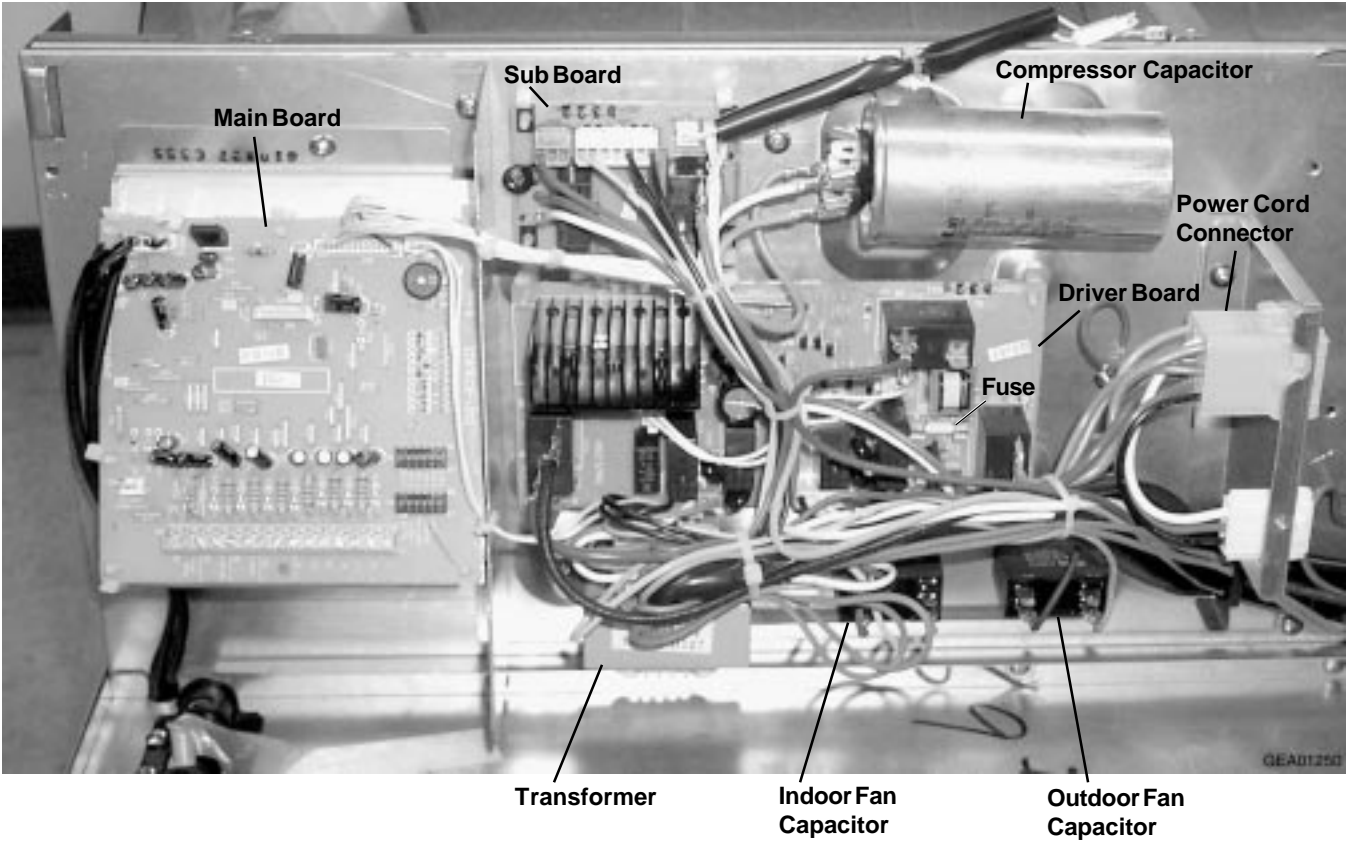

Main Board

Sub Board

Compressor Capacitor

Power Cord Connector

Driver Board

Fuse

Transformer

Indoor Fan Capacitor

Outdoor Fan Capacitor

Parts List

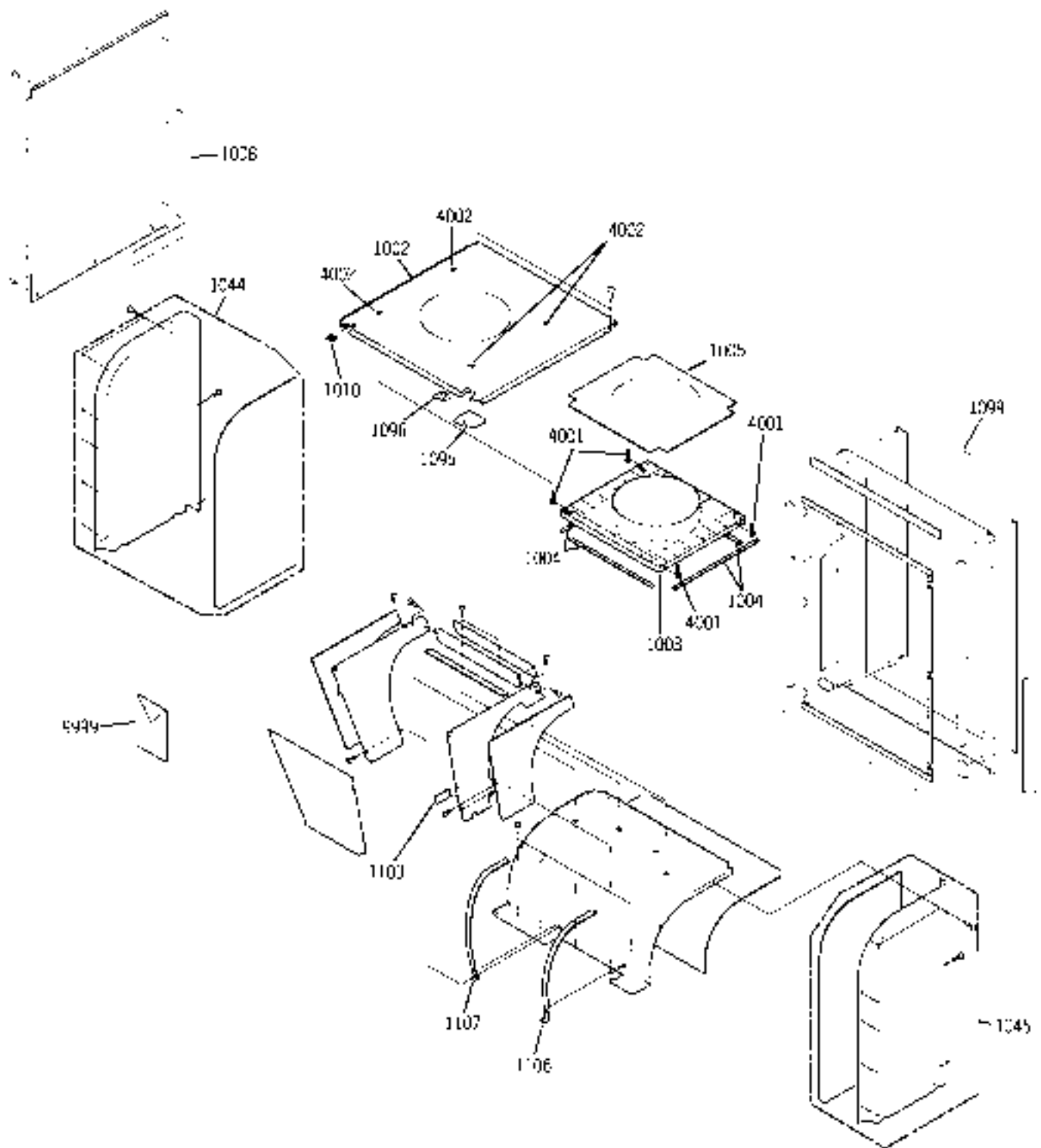

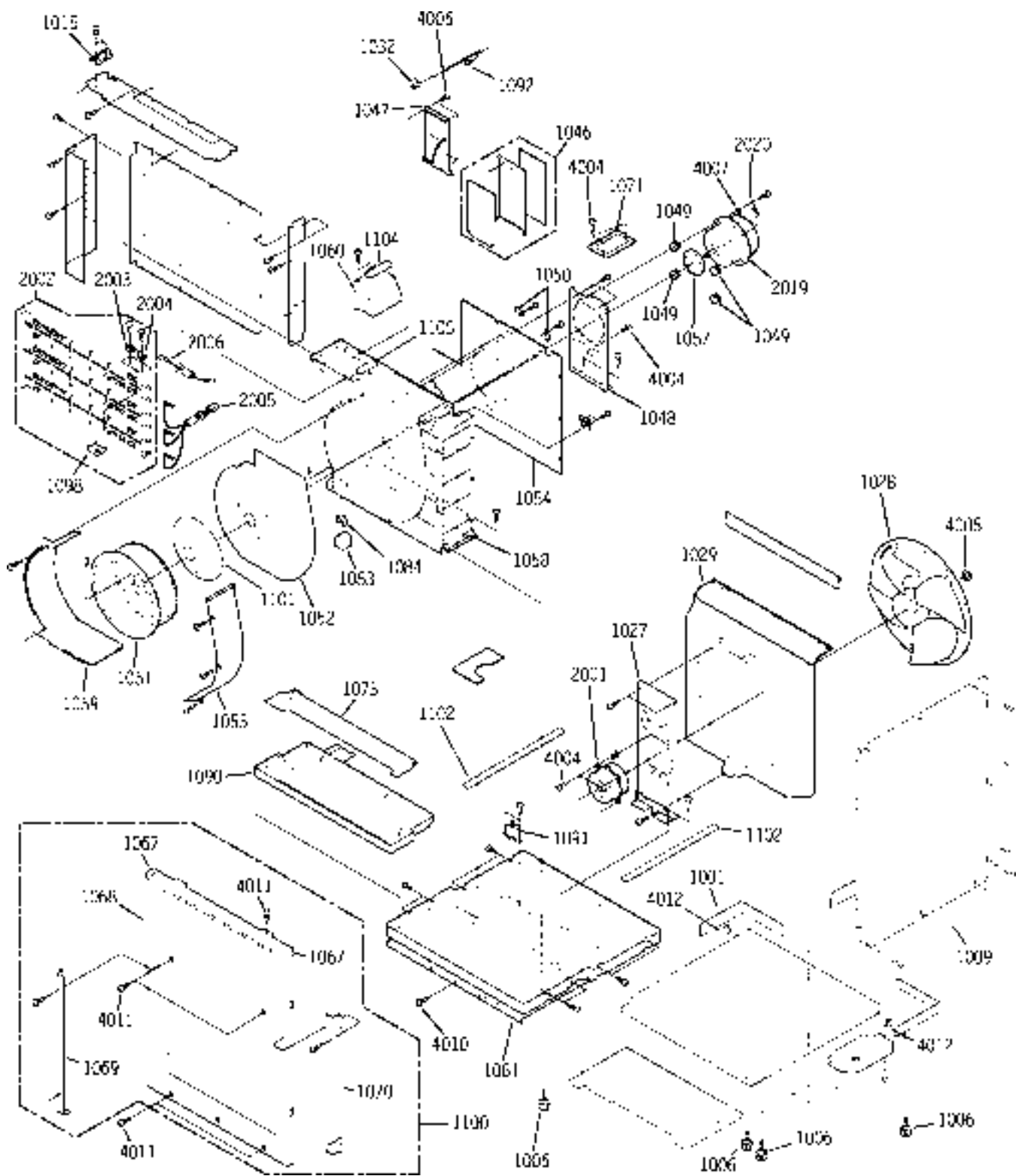

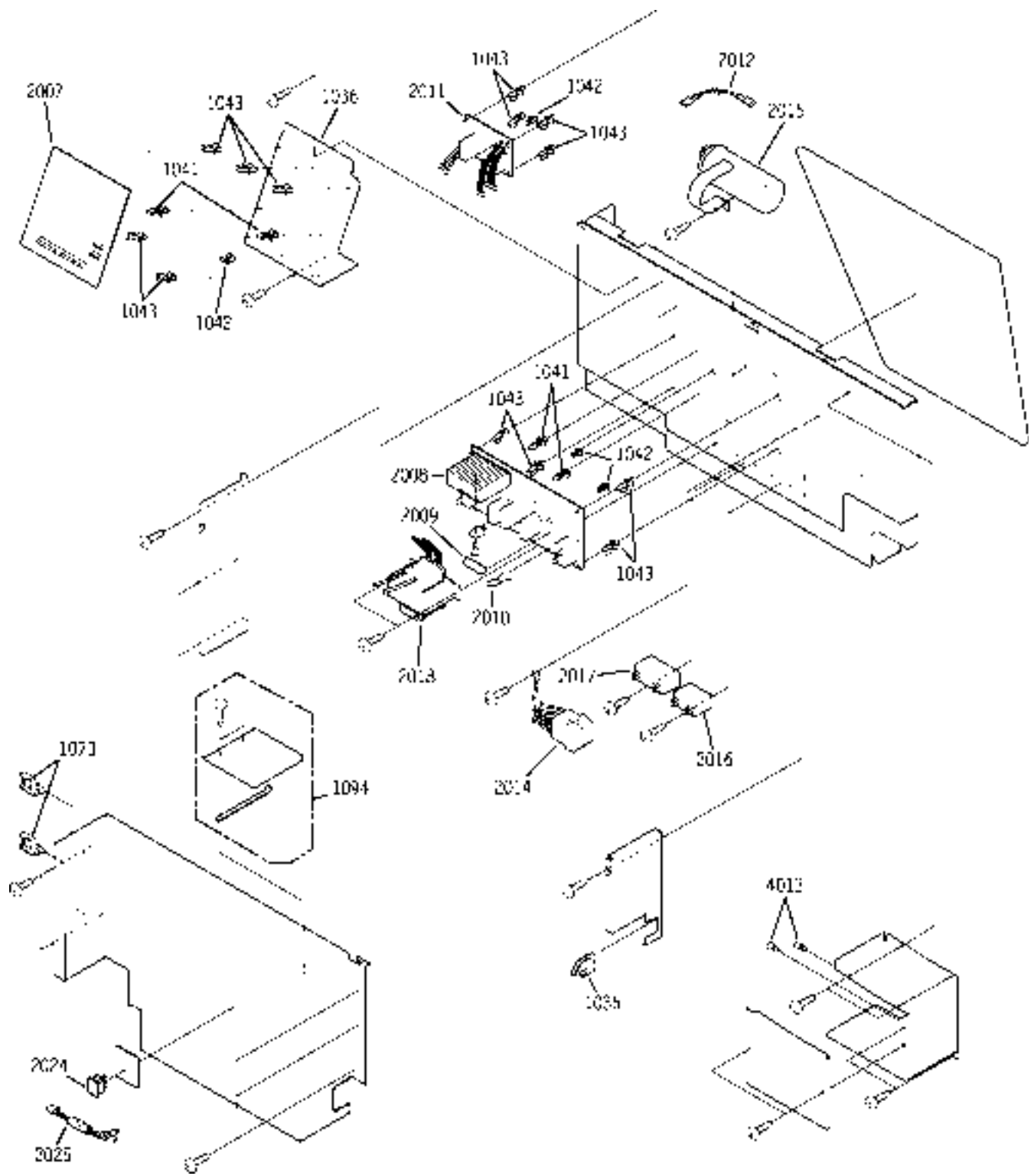

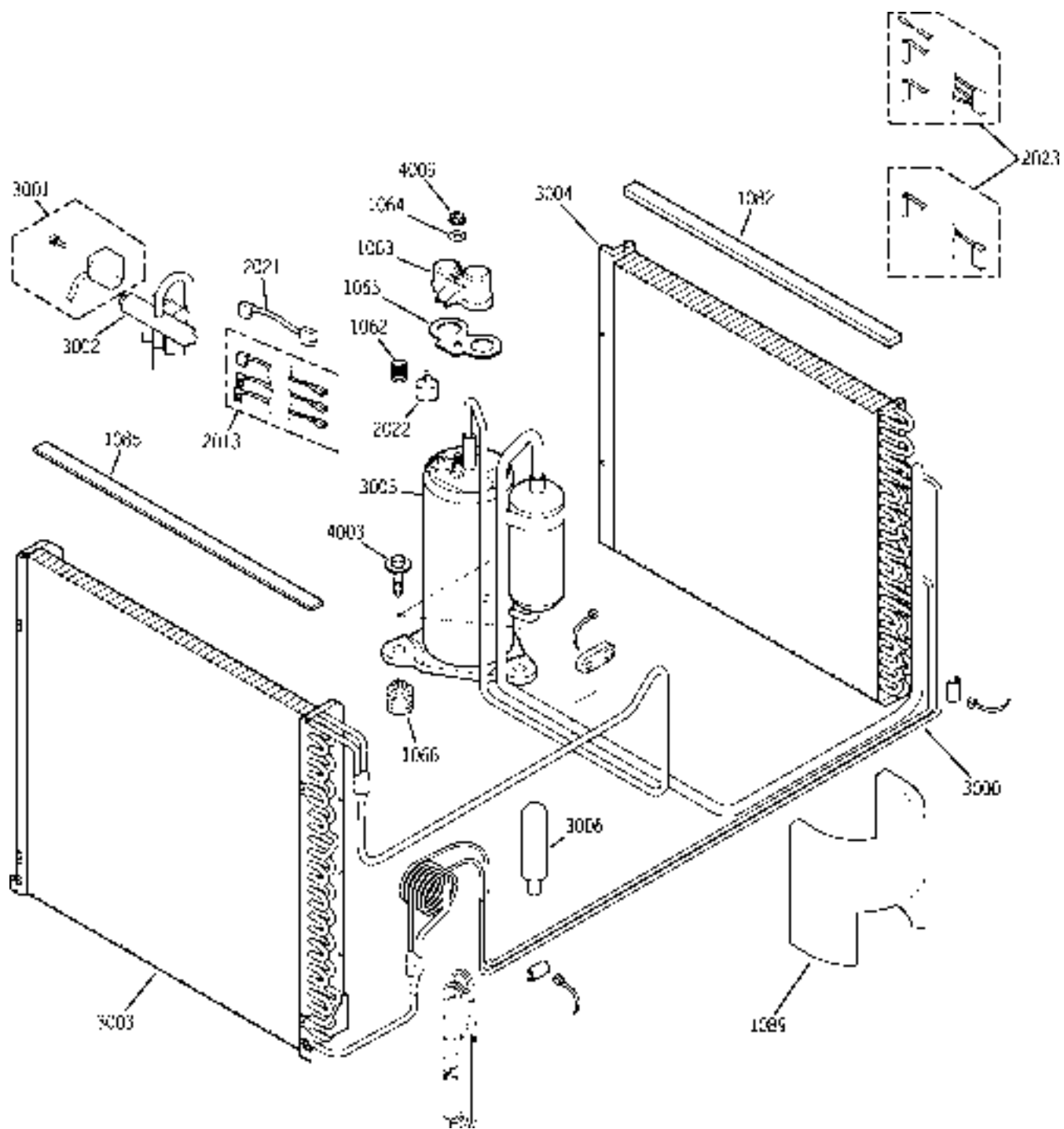

View #	Part #	Description	Quantity
1001	WJ82X10031	BOTTOM ANGLE ASS'Y	1
1002	WJ82X10028	CABINET TOP PLATE	1
1003	WJ50X10007	DUCT CONNECTOR	1
1004	WJ45X10017	DUCT INSULATOR	4
1005	WJ45X10018	DUCT INSULATOR	1
1006	WJ01X10172	ADJUSTER	4
1008	WJ82X10033	CABINET SIDE PLATE L	1
1009	WJ82X10034	CABINET SIDE PLATE R	1
1010	WJ03X10007	WIRE HOLDER	1
1015	WJ79X10074	DAMPER LEVER COVER	1
1027	WJ65X10052	MOTOR ANGLE	1
1028	WJ73X10060	PROPELLER FAN	1
1029	WJ76X10107	CONDENSER SHROUD	1
1032	WJ14X10031	DAMPER LEVER	1
1035	WJ03X10033	WIRE HOLDER	1
1036	WJ01X10174	PWB HOLDER	1
1041	WJ01X10043	SPACER	4
1042	WP01X10010	SPACER	10
1043	WJ01X10155	SPACER	7
1044	WJ01X10168	DIVIDER L ASS'Y	1
1045	WJ01X10169	DIVIDER R ASS'Y	1
1046	WJ70X10040	DAMPER ASS'Y	1
1047	WJ70X10036	DAMPER FRAME	1
1048	WJ65X10050	ID MOTOR MOUNT	1
1049	WJ01X10034	MOTOR CUSHION	4
1050	WJ01X10159	CLAMP	2
1051	WJ73X10059	CENTRIFUGAL FAN	1
1052	WJ79X10079	HOUSING COVER A	1

1053	WJ79X10075	HOUSING COVER B	1
1054	WJ45X10024	INSULATOR	1
1057	WJ01X10170	MOTOR RUBBER	1
1058	WJ76X10108	FAN HOUSING	1
1059	WJ76X10109	FAN HOUSING B	1
1060	WJ76X10110	FAN HOUSING C	1
1061	WJ89X10044	BASE PAN ASS'Y	1
1062	WJ02X10001	PROTECTOR SPRING	1
1063	WJ79X10013	TERMINAL COVER	1
1064	WJ01X10003	GASKET WASHER	1
1065	WJ43X10003	TERMINAL GASKET	1
1066	WJ01X10046	COMPRESSOR CUSHION	3
1067	WJ01X10171	CORNER CAP	2
1068	WJ71X10268	FRONT PANEL	1
1069	WJ05X10029	FILTER GUIDE L	1
1070	WJ05X10030	FILTER GUIDE R	1
1071	WJ65X10051	BRACE	1
1073	WP01X10009	CORD HOLDER L	2
1075	WJ79X10076	DRAIN COVER	1
1082	WJ45X10025	EVAPORATOR INSULATOR	1
1083	WJ40X10014	BULKHEAD INSULATOR	1
1084	WJ40X10015	BULKHEAD INSULATOR	1
1085	WJ45X10026	CONDENSER INSULATOR	1
1089	WJ79X10017	COMPRESSOR COVER	1
1090	WJ70X10037	DRAIN TRAY	1
1091	WJ58X10017	DRAIN VALVE	1
1092	WJ37X10029	DAMPER WIRE	1
1094	WJ11X10008	PLATE ASS'Y	1
1095	WJ11X10007	TOP PLATE SEAL 2	1

1096	WJ60X10002	TOP PLATE SEAL 1	1
1098	WJ03X10032	PROTECTOR HOLDER	1
1099	WJ90X10043	CABINET BACK ASS'Y	1
1100	WJ82X10035	FRONT PANEL ASS'Y	1
1101	WJ79X10078	HOUSING COVER	1
1102	WJ60X10005	BASE PAN SEAL	2
1103	WJ60X10008	FAN HOUSING SEAL A	1
1104	WJ60X10007	FAN HOUSING SEAL B	1
1105	WJ60X10006	FAN HOUSING SEAL C	1
1106	WJ60X10010	DUCT SEAL R	1
1107	WJ60X10009	DUCT SEAL L	1
2001	WJ73X10061	FAN MOTOR	1
2002	WJ70X10038	HEATER K	1
2003	WP28X10005	PROTECTOR	1
2004	WP28X10007	PROTECTOR	1
2005	WJ37X10030	HEATER CONNECTOR	1
2006	WJ36X10010	HEATER WIRE	1
2007	WJ26X10070	MAIN BOARD ASS'Y	1
2008	WJ26X10071	DRIVE BOARD ASS'Y	1
2009	WP23X10003	FUSE	1
2010	WP27X10002	VARISTOR	1
2011	WJ26X10072	SUB BOARD ASS'Y	1
2012	WJ37X10026	LEAD WIRE	1
2013	WJ36X10011	COMP. WIRING	1
2014	WJ36X10012	CONNECTOR K	1
2015	WJ20X0748	RUNNING CAPACITOR	1
2016	WP20X10005	FAN MOTOR CAPACITOR	1
2017	WJ20X10070	FAN MOTOR CAPACITOR	1
2018	WP27X10023	TRANSFORMER	1
2019	WJ73X10062	FAN MOTOR	1

2020	WJ37X10027	LEAD WIRE	1
2021	WJ27X10001	LEAD WIRE	1
2022	WP23X10005	PROTECTOR, COMPRESSOR	1
2023	WJ28X10027	THERMISTOR ASS'Y	1
2024	WJ26X10039	FAN SWITCH	1
2025	WJ37X10028	LEAD WIRE	1
3000	WJ53X0128	CAP. TUBE CUT TO 11.5"	1
3001	WJ31X10011	COIL	1
3002	WJ58X10020	REVERSE VALVE	1
3003	WJ88X10078	CONDENSER ASS'Y	1
3004	WJ87X10085	EVAPORATOR ASS'Y	1
3005	WJ98X10006	COMPRESSOR	1
3006	WJ46X10003	RECEIVER	1
4001	WJ01X10164	ADJUSTABLE BOLT	4
4002	WJ01X10165	ADJUSTABLE NUT	4
4003	WJ01X10031	STUD BOLT	3
4004	WJ01X10037	SPECIAL SCREW	11
4005	WJ01X10041	SPECIAL NUT	1
4006	WJ01X10056	SPECIAL SCREW	1
4007	WJ01X10166	SPECIAL SCREW	4
4009	WJ01X10010	SPECIAL NUT	1
4010	WJ01X10175	SPECIAL SCREW	1
4011	WJ01X10176	SPECIAL SCREW	6
4012	WJ01X10177	SPECIAL SCREW	2
4013	WJ01X10178	SPECIAL SCREW	2
9999	31-60807	MINI-MANUAL	1
9999	49-7419	USE & CARE MANUAL	1

Care and Cleaning

Warning: Turn the Zoneline off and disconnect the power supply before cleaning.

Indoor/Outdoor Coils

The exhaust coils on the Zoneline should be checked regularly. If they are clogged with dirt or soot, they may be professionally steam cleaned, a service available through your GE service center. You will need to remove the unit from the case to inspect the coils because the dirt buildup occurs on the exhaust side.

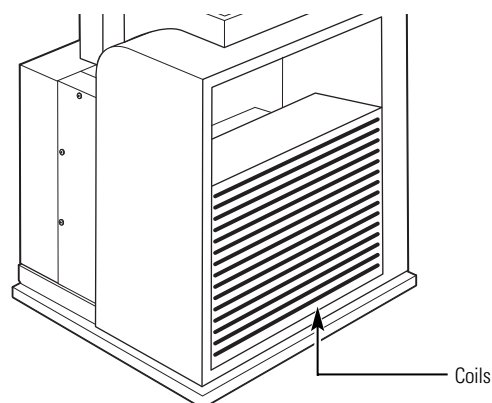

Have the coils cleaned regularly.

Base Pan

In some installations, dirt or other debris may be blown into the unit from the outside and settle in the base pan (the bottom of the unit).

In some areas of the United States, a "jell-like" substance may be present in the base pan.

Check it periodically and clean, if necessary.

Air Filters

Note: To maintain optimum performance, change the filter at least every 30 days.

The most important thing you can do to maintain the Zoneline is to change the filter at least every 30 days. Dirty filters reduce cooling, heating, and air flow.

Changing the filter will: Decrease cost of operation, save energy, prevent clogged heat exchanger coils, and reduce the risk of premature component failure.

Caution: Do not operate the Zoneline without the filter in place. If a filter becomes torn or damaged, it should be replaced immediately.

Operating without the filter in place or with a damaged filter will allow dirt and dust to reach the indoor coil and reduce the cooling, heating, airflow, and efficiency of the unit.

Replacement filters should be purchased from your local retailer where air conditioner and furnace accessories are sold.

Filter size required is 20" x 20" x 1".

To remove and replace the filter:

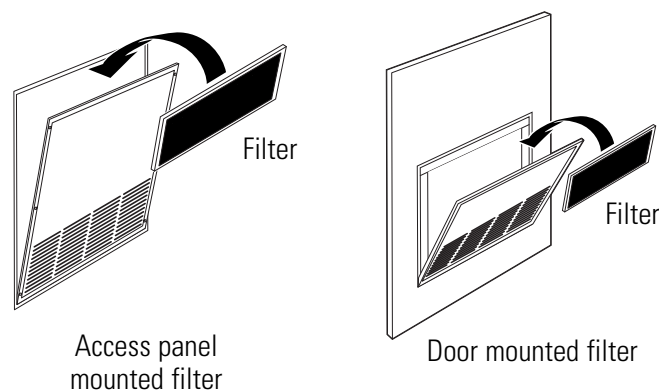
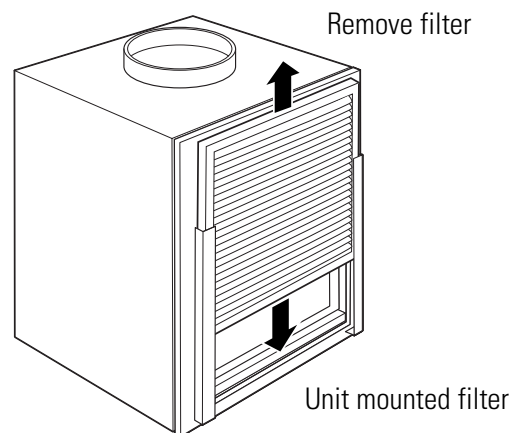

Warranty



All warranty service provided by our Factory Service Centers, or an authorized Customer Care® technician. To schedule service, on-line, 24 hours a day, visit us at GEAppliances.com, or call 800.GE.CARES (800.432.2737). For service in Canada, call 1.800.361.3400.

Staple your receipt here. Proof of the original purchase date is needed to obtain service under the warranty.

For The Period Of:	GE Will Replace:
<p>One Year From the date of the original purchase</p>	<p>Any part of the Zoneline which fails due to a defect in materials or workmanship. During this full one-year warranty, GE will also provide, free of charge, all labor and on-site service to replace the defective part.</p>
<p>Five Years From the date of the original purchase</p>	<p>Any part of the sealed refrigerating system (the compressor, condenser, evaporator and all connecting tubing) which fails due to a defect in materials or workmanship. During this full five-year sealed refrigerating system warranty, GE will also provide, free of charge, all labor and on-site service to replace the defective part.</p>
<p>Five Years From the date of the original purchase</p>	<p>For the second through the fifth year from the date of original purchase, GE will replace certain parts that fail due to a defect in materials or workmanship. Parts covered are fan motors, switches, thermostats, heater, heater protectors, compressor overload, solenoids, circuit boards, auxiliary controls, thermistors, frost controls, ICR pump, capacitors, varistors and indoor blower bearing. During this limited four-year parts warranty, you will be responsible for any labor or on-site service costs.</p>

What GE Will Not Cover:

- Service trips to your site to teach you how to use the product.
- Improper installation.
If you have an installation problem, or if the air conditioner is of improper cooling or heating capacity for the intended use, contact your dealer or installer. You are responsible for providing adequate electrical connecting facilities.
- In commercial locations, labor necessary to move the unit to a location where it is accessible for service by an individual technician.
- Failure or damage resulting from corrosion due to installation in an environment containing corrosive chemicals.
- Replacement of fuses or resetting of circuit breakers.
- Filters.
- Failure of the product resulting from modifications to the product or due to unreasonable use including failure to provide reasonable and necessary maintenance.
- Failure or damage resulting from corrosion due to installation in a coastal environment, except for models treated with special factory-applied anti-corrosion protection as designated in the model number.
- Damage to product caused by improper power supply voltage, accident, fire, floods or acts of God.
- Incidental or consequential damage caused by possible defects with this air conditioner.

This warranty is extended to the original purchaser and any succeeding owner for products purchased for use within the USA and Canada. In Alaska, the warranty excludes the cost of shipping or service calls to your site.

Some states or provinces do not allow the exclusion or limitation of incidental or consequential damages. This warranty gives you specific legal rights, and you may also have other rights which vary from state to state or province to province. To know what your legal rights are, consult your local, state or provincial consumer affairs office or your state's Attorney General.

Warrantor: General Electric Company. Louisville, KY 40225

