

Dehumidifier

Contents

Adapter Plug	3	Model and Serial Numbers	2, 5
Air Direction	5	Problem Solver	6
Appliance Registration	2	Repair Service	7
Auto Defrost	4	Safety Instructions	2
Care and Cleaning	5	User Maintenance Instructions	5
Condenser Coils	6	Warranty	Back Cover
Control Settings	4,5	Water Overflow Control	5
Electrical Requirements	3		
Extension Cords	3		
Grille and Cabinet	6		
Grounding	3	GE Answer Center®	
Humidity Control	4,5	800.626.2000	

Models **AHD15**
AHD24
AHD38

GE Quality Product

Help us help you...

Before using your dehumidifier, read this book carefully.

It is intended to help you operate and maintain your new dehumidifier properly.

Keep it handy for answers to your questions.

If you don't understand something or need more help, write (include your phone number):

Consumer Affairs
GE Appliances
Appliance Park
Louisville, KY 40225

Write down the model and serial numbers.

You'll find them on a label in front of the bucket at the back of the dehumidifier. See page 5.

These numbers are also on the Consumer Product Ownership Registration Card that came with your dehumidifier. Before sending in this card, please write these numbers here:

Model Number

Serial Number

Use these model and serial numbers in any correspondence or service calls concerning your dehumidifier.

If you received a damaged dehumidifier...

Immediately contact the dealer (or builder) that sold you the dehumidifier.

Save time and money. Before you request service . . .

Check the Problem Solver on page 7. It lists causes of minor operating problems that you can correct yourself.

Important Safety Instructions

Read all instruction before us@ this appliance.

When using this appliance, always exercise basic safety precautions, including the following:

- **Use this appliance only for its intended purpose** as described in this Use and Care Guide.
- **This dehumidifier must be properly grounded before it is used.** See grounding instructions on page 3.
- **Never operate this appliance in an area that is likely to accumulate standing water.** If this condition develops, for your safety disconnect the power supply before stepping into the water.
- **Never unplug your dehumidifier by pulling on the power cord.** Always grip plug **firmly** and pull straight out **from** the receptacle.
- **Repair or replace immediately all electric service cords that have become frayed or otherwise damaged.** Do not use a cord that shows cracks or abrasion damage along its length or at either the plug or connector end.

SAVE THESE INSTRUCTIONS

Electrical Safety—IMPORTANT... Please Read Carefully.

How to connect electricity

For personal safety, this appliance must be properly grounded.

The power cord of this appliance is equipped with a three-prong (grounding) plug which mates with a standard three-prong (grounding) wall outlet (Fig. 1) to minimize the possibility of electric shock hazard from this appliance.

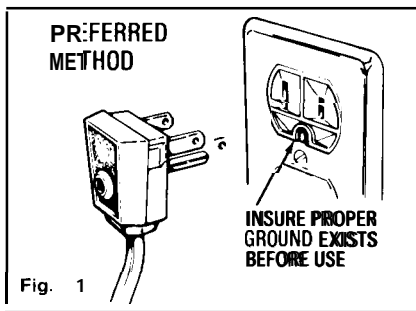

Have the wall outlet and circuit checked by a qualified electrician to make sure the outlet is properly grounded.

Where a standard two-prong wall outlet is encountered, it is your personal responsibility and obligation to have it replaced with a properly grounded three-prong wall outlet.

DO NOT, UNDER ANY CIRCUMSTANCES, CUT OR REMOVE THE THIRD (GROUND) PRONG FROM THE POWER CORD.

Use of adapter plug (115-volt units)

Because of potential safety hazards under certain conditions, we strongly recommend against use of an adapter plug. However, if you still elect to use an adapter, where local codes permit, a **TEMPORARY CONNECTION** maybe made to a properly grounded {we-prong wall outlet by use of a **UL listed adapter** (Fig. 2) available at most local hardware stores.

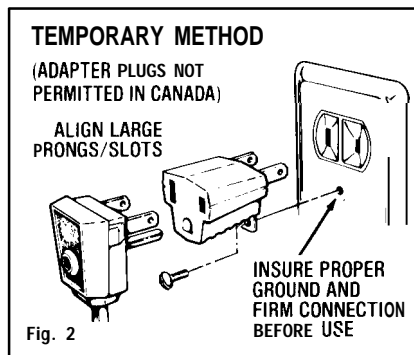

The larger slot in the adapter must be aligned with the larger slot in the wall outlet to provide proper polarity in the connection of the power cord.

CAUTION: Attaching an adapter ground terminal to wall outlet cover screw does not ground appliance unless cover screw is metal, and not insulated, and wall outlet is grounded through house wiring. You should have circuit checked by a qualified electrician to make sure the outlet is properly grounded.

When disconnecting the power cord from the adapter, always hold the adapter with one hand. If this is not done, the adapter ground terminal is very likely to break with repeated use.

Should the adapter ground terminal break, DO NOT USE the appliance until a proper ground has again been established.

Use of extension cords not recommended

Because of potential safety hazards under certain conditions, we strongly recommend against the use of an extension cord. However, if you still elect to use an extension cord, it is absolutely necessary that it be a **UL listed 3-wire grounding type appliance extension cord** having a grounding type plug and outlet and that the electrical rating of the cord be 15 amperes (minimum) and 120 volts.

Operating Your Dehumidifier

How it works

Moist, humid air is drawn over a cold, refrigerated dehumidifying coil. Moisture in the air condenses on this coil and then drains into a bucket (or through a hose into a drain). Dry, clean air is then drawn over the condenser where it is actually heated several degrees and discharged out the front grille into the room. It is normal for the surrounding air to become slightly warmer as the dehumidifier operates. This warming effect further reduces the relative humidity of the surrounding air.

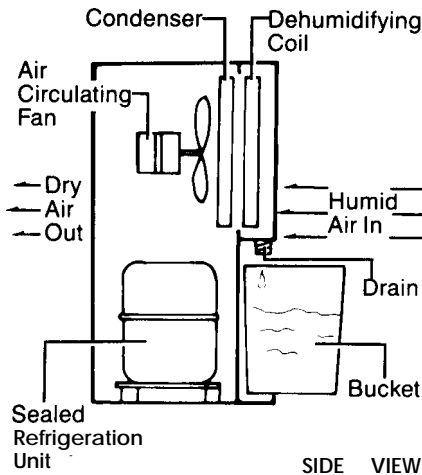

When locating the dehumidifier, be sure to place it where there is no restriction to the air flow either into the coil at the rear or from the front grille. Good air circulation through the appliance is essential to efficient operation.

Humidity Control

A Humidity Control, built into your dehumidifier, automatically maintains a selected humidity level. It starts the dehumidifier when the humidity is high and shuts it off when the humidity is low.

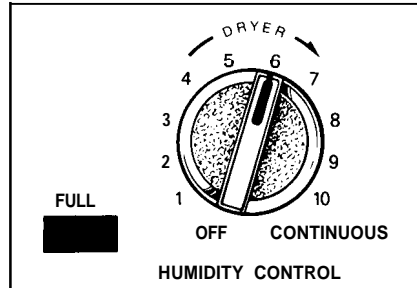

For maximum dehumidification

The Humidity Control has settings from "1" to "10." Turning the control knob to "10" provides the greatest amount of dehumidification, turning it to "1" provides the least.

Even when the Humidity Control is set at "10," the dehumidifier will run continuously during particularly humid periods due to seepage of humid air into the room through the walls, around doors and windows and through the use of clothes dryers and similar equipment that add moisture to the air. The continuous operation of the dehumidifier during such humid periods is normal and necessary to maintain desired conditions.

The first 3 or 4 days that you have your dehumidifier, run it at "10" to allow it to remove large amounts of accumulated moisture from the room. When the room has reached the desired humidity level, the amount of moisture removed from the air will be considerably less. Rotate the Humidity Control knob toward "1" until the dehumidifier shuts off. The Humidity Control will automatically maintain the desired dryness in the room.

When the dehumidifier is first turned on and the dehumidifying coil is dry, a light coating of frost will appear. This is normal. The frost will usually disappear in 30 to 45 minutes.

If room temperature goes below 65°F., frost may accumulate on the dehumidifying coil, reducing the unit's operating efficiency. On Auto Defrost models, the compressor will shut off automatically until the coil reaches the correct operating temperature. The fan will continue to run to aid in the defrosting. For models without the Auto Defrost feature, we recommend that you turn the Humidity Control knob to "1" to allow the coil to defrost. Then turn it back to your desired setting.

The Auto Defrost feature is also designed to prevent excessive on-off cycling, and under certain conditions may allow the frost to remain on the coil for some time before the compressor shuts off and the frost is cleared. This is not unusual.

To remove collected water

Your dehumidifier has a plastic bucket that catches the water that is removed from the air, an automatic water overflow control, and a signal light that glows when the bucket is full.

On some models, weight of water in the bucket triggers a switch at the bottom rear of the dehumidifier that stops the unit and turns the FULL light on when the bucket is nearly full.

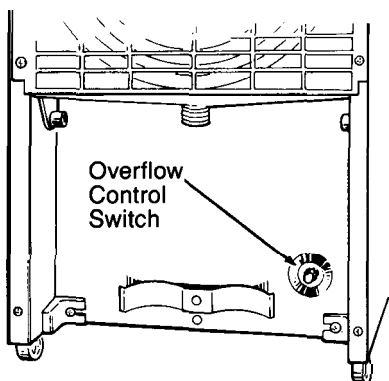

Before removing the bucket to empty it, turn the Humidity Control knob to "1." This will prevent the dehumidifier from operating when the bucket is not in place.

After emptying the bucket, hang it on the bucket supports on each side and push it all the way in.

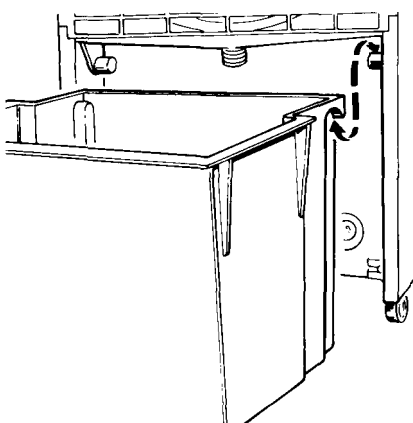

After replacing the bucket, be sure to turn the Humidity Control knob back to the desired setting.

On other models, a float rises and activates the water overflow control that turns the FULL light on and stops dehumidification before the bucket overflows.

Before removing the bucket, move the control cord attached to the float to the OFF (up) position. This will keep the float up and prevent the dehumidifier from operating when the bucket is not in place.

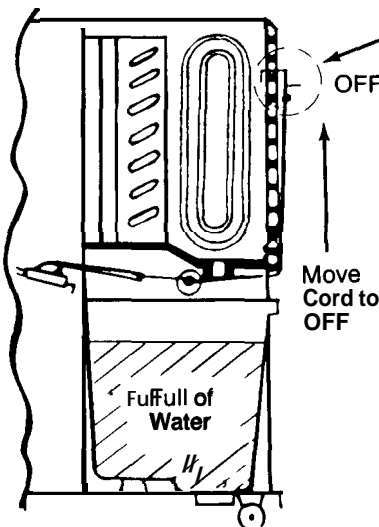

After replacing the bucket, move the control cord to the ON (down) position and make sure the float hangs freely inside the bucket.

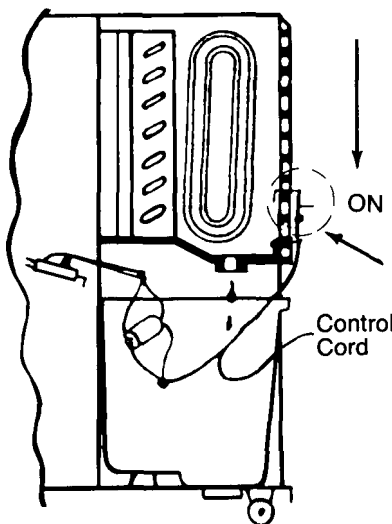

For continuous drain-off of water

Attach a suitable length of standard garden hose (not supplied). A male thread is provided on the drain or water bucket.

Care & Cleaning

Unplug dehumidifier before cleaning.

Occasionally the dehumidifier will require cleaning. Use a vacuum cleaner attachment or brush to clean the front grille. The best way to clean the dehumidifying coil is by the use of a soft brush when the soil is soft and wet. (If allowed to dry and harden, it will be difficult to remove and must be soaked and softened.)

Do not allow a lot of water to enter the electrical/machine compartment through the circular opening behind the coil. Use a squirt bottle or syringe so you can control the water.

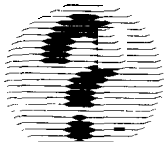

Questions? Use This Problem Solver

PROBLEM	POSSIBLE CAUSE AND REMEDY
DEHUMIDIFIER DOES NOT OPERATE	<ul style="list-style-type: none">. Not plugged in. Plug may have been bumped loose.• If plugged in, fuse could have blown or circuit breaker may have tripped.• Frost buildup on dehumidifying coil (on models without Auto Defrost), caused by room temperature dropping below 65°F. Turn Humidity Control knob to "1" to allow coil to defrost, then reset it when the room warms up.
DEHUMIDIFIER "DOES NOT DRY THE AIR AS IT SHOULD"	<ul style="list-style-type: none">• When the dehumidifier was first installed, not enough time was allowed for it to remove the large amount of moisture that had accumulated in the room. As long as three or four days, with the Humidity Control knob set at "10," maybe required to achieve and maintain the desired dryness.• Objects blocking front and/or back of dehumidifier will restrict air flow and reduce efficiency.• Humidity Control maybe set too low. Turn control knob to a higher setting.• Doors and/or windows may not be tightly closed.• Clothes dryer may be blowing moisture-laden air into the room.
WATER ON FLOOR	<p><i>On models with float-activated water overflow control</i></p> <ul style="list-style-type: none">• connection may be loose if hose is attached to dehumidifier for continuous drain-off.. Float ball may not be suspended freely in bucket.• Bucket may not be pushed all the way into the dehumidifier. <p><i>On other models</i></p> <ul style="list-style-type: none">• Bucket not hung properly from bucket supports. See page 5.

If you need more help.. call, toll free:
GE Answer Center®
800.626.2000
consumer information service

If You Need Service

To obtain service, see your warranty on the back page of this book.

We're proud of our service and want you to be pleased. If for some reason you are not happy with the service you receive, here are three steps to follow for further help.

FIRST, contact the people who serviced your appliance. Explain why you are not pleased. In most cases, this will solve the problem.

NEXT, if you are still not pleased, write all the details—including your phone number—to:

Manager, Consumer Relations
GE Appliances
Appliance Park
Louisville, Kentucky 40225

FINALLY, if your problem is still not resolved, write:

Major Appliance
Consumer Action Panel
20 North Wacker Drive
Chicago, Illinois 60606

YOUR GENERAL ELECTRIC DEHUMIDIFIER WARRANTY

Save proof of original purchase date such as your sales slip or cancelled check to establish warranty period.

WHAT IS COVERED

LIMITED ONE-YEAR WARRANTY

For one year from date of original purchase, we will provide, free of charge, parts and service labor to repair or replace **any part of the dehumidifier** that fails because of a manufacturing defect.

LIMITED ADDITIONAL FOUR-YEAR WARRANTY

For the second through fifth year from date of original purchase, we will provide, free of charge, parts and service labor to repair or replace **any part of the sealed system** (the compressor, condenser, dehumidifying coil and all connecting tubing) that fails because of a manufacturing defect.

For each of the above warranties: You must take the dehumidifier to a General Electric Factory Service Center or a General Electric Customer Care™ Servicer and pick it up following service. In-home service is also available, but you must pay for the service technician's travel costs to your home.

This warranty is extended to the original purchaser and any succeeding owner for products purchased for use in the 48 mainland states, Alaska, Hawaii and Washington, D.C.

All warranty service will be provided by our Factory Service Centers or by our authorized Customer Care™ servicers during normal working hours.

Look in the White or Yellow Pages of your telephone directory for GENERAL ELECTRIC COMPANY, GENERAL ELECTRIC FACTORY SERVICE, GENERAL ELECTRIC-HOTPOINT FACTORY SERVICE or GENERAL ELECTRIC CUSTOMER CARE@ SERVICE.

WHAT IS NOT COVERED

- Service trips to your home to teach you how to use the product.

Read your Use and Care material. If you then have any questions about operating the product, please contact your dealer or our Consumer Affairs office at the address below, or call, toll free:

GE Answer Center®
800.626.2000
consumer information service

- Improper installation.

If you have an installation problem, contact your dealer or installer. You are responsible for providing adequate electrical, plumbing and other connecting facilities.

- Replacement of house fuses or resetting of circuit breakers.

• Failure of the product if it is used for other than its intended purpose or used commercially.

- Damage to product caused by accident, fire, floods or acts of God.

WARRANTOR IS NOT RESPONSIBLE FOR CONSEQUENTIAL DAMAGES.

Some states do not allow the exclusion or limitation of incidental or consequential damages, so the above limitation or exclusion may not apply to you. This warranty gives you specific legal rights, and you may also have other rights which vary from state to state. To know what your legal rights are in your state, consult your local or state consumer affairs office or your state's Attorney General.

Warrantor: General Electric Company

**If further help is needed concerning this warranty, write:
Manager—Consumer Affairs, GE Appliances, Louisville, KY 40225**