

— GET TO KNOW US —



haierappliances.com

# Haier

Born for the city.™

2023  
Appliance Catalog



**#1 major  
appliance  
brand in  
the world\***



## Haier

Appliance Park  
Louisville, KY 40225  
haierappliances.com

©2023 GE Appliances, a Haier Company.  
T PA 97259

\*Euromonitor 2021





The city is where we belong.

Its energy and grit are what inspire us.

From the architecture to the fast-paced lifestyle.

It's what pushes us to engineer appliances  
for a new way of living.

Appliances that combine technology,  
international design and city hustle.

We're the only appliance brand  
designed for this place.

**We're Haier, and we're born for the city.**





# A look inspired by the world that surrounds us.

---

Experience appliances that capture the architecture, energy and creativity that define modern living.





# Experience the #1 Brand of Major Appliances for 14 years in a row.\*

Designed for small spaces, these appliances combine the latest kitchen features and a contemporary look, all in the convenient sizes you need.

Left to right:

QDT125SSLSS (dishwasher) — See pg. 27

HMV1472BHS (microwave oven) — See pg. 25

HEBF100BXS (beverage centers) — See pg. 19

\*Euromonitor 2021







## Discover new possibilities in a small-space kitchen.

These compact appliances are designed for creative individuals who would rather be exploring a vibrant city than sitting at home.

Left to right:

QHE16HYPFS (refrigerator) — See pg. 17

QDT125SSLSS (dishwasher) — See pg. 27

HMV1472BHS (microwave oven) — See pg. 25

QAS74ORMSS (range) — See pg. 23



# Kitchen conveniences, wherever you spend time.

Now you can add simple, stylish appliances anywhere, even in the most unexpected places.

Left to right:

HEBF100BXS (beverage center) — See pg. 19

QDT125SSLSS (dishwasher) — See pg. 27







## Table of Contents

---

Refrigeration .....	14
Cooking .....	20
Dishwashers .....	26
Comfort Products.....	28
Specifications .....	34



Compliant with the Americans with Disabilities Act



ENERGY STAR® certified

*GE Appliances helps you conserve energy and save money. We have been an ENERGY STAR® Partner since 2001. We are committed to creating energy-efficient, high-performance household appliances.*



WiFi compatible

*Appliances with built-in WiFi powered by SmartHQ™ offer remote monitoring and enhanced features are indicated by this icon.*



Voice Activation

*This mark indicates that a product has voice assistance capabilities.*





# Refrigeration

The high-rise on your kitchen's skyline.



# REFRIGERATORS

## FEATURES



### SLEEK DESIGN WITH INTEGRATED HANDLE

Sharp lines, a tasteful stainless finish and a cool, integrated handle create a standout style that complements any kitchen.



### QUICK COOL & QUICK FREEZE FUNCTIONS

Just keeping it fresh. These easy-set functions accelerate the cooling/freezing of newly stored foods and protect those already refrigerated or frozen.



### EDGE-TO-EDGE GLASS SHELVES

Store more of your favorites and stay organized on every level with glass shelves that extend from wall to wall.



### FINGERPRINT RESISTANT STAINLESS

Get the look you want and keep it that way. Fingerprint resistant, stainless finish keeps your refrigerator looking fresh, clean and stylish.



### LED LIGHTING

In the city or in your kitchen, saving energy makes sense. LED lighting provides long-lasting, clear, bright light and is more energy efficient than incandescent lighting.



### ICEMAKER-READY

Equipped for an optional icemaker this icemaker ready refrigerator lets you decide whether to add the convenience of an automatic icemaker.



### EXTERNAL TEMPERATURE CONTROL

Precision technology gives you more control. External temperature control lets you easily manage fresh-food and freezer temperatures with an increase/decrease of 1° for each press.



### QUICK COOL AND FREEZE

Chill and freeze items in no time with a fast-cooling function in the refrigerator and rapid freeze function in the freezer.

See product overviews for model-specific features.



### QHE16HYP 16.8 CU. FT. ENERGY STAR® QUAD-DOOR REFRIGERATOR

- + Fits 33"-wide opening
- + Counter-depth design
- + Humidity control system
- + LED lighting
- + Icemaker ready
- + Quick Cool and Freeze
- + Digital thermostat
- + Edge-to-edge shelves

■ Fingerprint Resistant Stainless – QHE16HYPFS



### QJS15HYR 14.5 CU. FT. 4 DOOR REFRIGERATOR

- + Counter-depth design
- + Icemaker ready
- + Quick Cool and Quick Freeze functions
- + Cool Zone refrigerator drawer
- + Sleek design
- + Digital thermostat
- + Edge-to-edge shelves
- + Clear Door shelves
- + Freezer drawers
- + LED lighting

■ Fingerprint Resistant Stainless – QJS15HYRFS



# REFRIGERATORS



## HRB15N3BG 15 CU. FT. ENERGY STAR® REFRIGERATOR

- + Fits in 28"-wide opening
- + Reversible doors
- + LED lighting
- + Sabbath Mode functionality
- + Quick Cool and Quick Freeze functions
- + External capacitive touch temperature controls
- + Full-width crisper
- + Multi Zone Air Tower

■ Stainless – HRB15N3BGS



## HA10TG21S 9.8 CU. FT. TOP FREEZER REFRIGERATOR

- + Fits in 24"-wide opening
- + LED lighting
- + Adjustable spillproof glass shelves
- + Clear, humidity-controlled crisper drawers
- + Clear door bins

□ White – HA10TG21SW  
■ Stainless – HA10TG21SS  
■ Black – HA10TG21SB

# BEVERAGE & WINE CENTER

## FEATURES

### BEVERAGE CENTER



#### GLASS DOOR WITH BLACK CABINET & METAL DOOR TRIM

Looking good, inside and out. Glass door with black cabinet and metal door trim provides a sleek appearance and clear view of your beverages.



#### 4 FULL-WIDTH GLASS SHELVES TO ACCOMMODATE A VARIETY OF BOTTLES AND CANS

Choose a shelf to match your beverages. Four easy-to-clean, full-width glass shelves provide a flexible storage solution for bottles and cans.

### WINE CENTER



#### 44 WINE BOTTLE STORAGE CAPACITY

Enjoy this wine center with plenty of space to store all your favorite red and white wines, with three full-width and one half-width wooden shelves.



#### DUAL ZONE WINE

The dual zone beverage center has two independently controlled distinct zones that maintain temperatures between 41° and 61° F, keeping both red and white wines at the perfect serving temperature.

See product overviews for model-specific features.



## HEBF100BX 150-CAN BEVERAGE CENTER

- + Fits in 20-1/2"-wide opening
- + Glass door with black cabinet and metal door trim
- + Automatic LED interior light
- + 4 full-width glass shelves to accommodate a variety of bottles and cans
- + Temperature range 39°–55° F (average temperature range for middle shelf of unit)
- + Recessed handle
- + Security lock and key
- + Adjustable thermostat
- + Reversible door

■ Stainless – HEBF100BXS



## QWR04DGR WINE CENTER

- + 44 wine bottle storage capacity
- + Dual zone
- + Triple-pane glass door
- + Digital glass touch controls
- + Interior LED lighting
- + Flush handle
- + Sliding shelves
- + Door alarm
- + Power/Lighting controls

■ Black – QWR04DGRGB





# Cooking

---

The right ingredients for your modern tastes.



# FREE-STANDING RANGES

## FEATURES

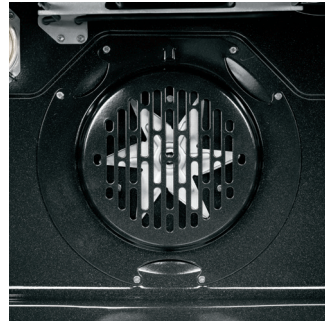

### CONVECTION

With this tech-savvy oven, you've got baking down. Rear fan and additional heating element distribute hot air throughout the oven for a faster, more even bake.



### HIDDEN BAKE ELEMENT

Busy lifestyles don't stop for cooking spills. Hidden bake element sits beneath a smooth surface, making cleaning fast and easy.



### SIMMER BURNER

Find the right balance in life and in cooking. Low heat delivers gentle, even cooking results for your most delicate foods.



### HEAVY-DUTY CONTINUOUS CAST-IRON GRATES

Go with your culinary flow. Continuous grates allow for easy movement of cookware, while providing even heat distribution with better heat retention.



### MODULAR BACKGUARD

Match the look with your style. Versatile design gives you the option of a traditional look or a slide-in appearance.

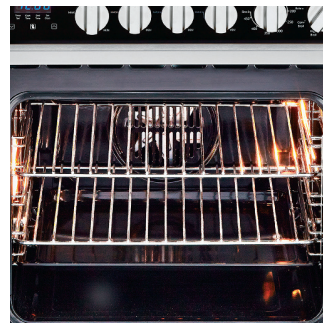

### DUAL LIGHTS

See your cooking skills in action. Dual lights spread bright, clear light throughout the oven for easy viewing.



### BROIL ELEMENT

Perfectly designed for perfect results. Broil element delivers concentrated heat for broiling a variety of foods.



### HEAVY-DUTY KNOBS

Designed to fit your life and style. Large, easy-to-operate knobs lend a high-end appearance, while their push-to-turn operation provides added safety.

See product overviews for model-specific features.



ADA COMPLIANT

### QGAS740

#### 24" 2.9 CU. FT. GAS RANGE WITH CONVECTION AND MODULAR BACKGUARD

- + Heavy-duty, continuous cast-iron grates
- + Modular backguard
- + Fan convection
- + Closed-oven broiling
- + Sealed burners
- + Perfect match with over-the-range microwave
- + Storage drawer
- + Incandescent interior lighting

■ Stainless – QGAS740RMSS



ADA COMPLIANT

### QAS740

#### 24" 2.9 CU. FT. ELECTRIC RANGE

- + Ceramic-glass cooking surface
- + Convection
- + Modular backguard
- + Hidden bake element
- + Easy-to-clean surface
- + Storage drawer
- + Perfect match with over-the-range microwave
- + Incandescent interior lighting

■ Stainless – QAS740RMSS

The Bluetooth® word mark and logos are registered trademarks owned by Bluetooth SIG, Inc. and any use of such marks by GE Appliances is under license. Other trademarks and trade names are those of their respective owners.



# WALL OVEN

## FEATURES



### HALOGEN LIGHTS

See your cooking skills in action. Halogen lights spread bright, clear light throughout the oven for easy viewing.



### BROIL ELEMENT

Perfectly designed for perfect results. Stainless steel heat reflector provides even heat distribution for consistently better broiling.

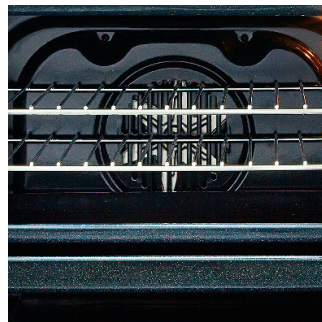

### TRUE EUROPEAN CONVECTION

Worldly design adds style and functionality. Rear fan and additional heating element distribute hot air throughout the oven for a faster, more even bake.



### HIDDEN BAKE ELEMENT

Busy lifestyles don't stop for cooking spills. Hidden bake element sits beneath a smooth surface, making cleaning fast and easy.



### LCD WITH SENSOR TOUCH CONTROL

This ultra-modern feature delivers optimum functionality. Highly responsive, finger touch controls allow for precise operation of all oven functions.



### SELF-CLEANING OVEN

Remove the mess and the hassle. Self-cleaning oven gets rid of cooking spills for a quick and easy oven clean without scrubbing.

See product overviews for model-specific features.



HCW2360

### 24" SINGLE 2.0 CU. FT. TRUE EUROPEAN CONVECTION OVEN

- + LCD with sensor touch control
- + 10 cooking modes
- + 2 racks with 5 shelf positions
- + Self-cleaning oven
- + My Favorite Recipe option
- + Halogen interior lighting
- + Hidden bake element
- + Safety lock system
- + Broil set included

■ Stainless – HCW2360AES

# MICROWAVE OVENS

## FEATURES



### SENSOR COOKING

Smart tech takes the guesswork out of cooking. Sensor cooking feature adjusts cooking time and power level automatically, ensuring food is cooked perfectly.



### RECIRCULATING AND VENTING OPTIONS

You take care of the cooking. It takes care of the smell. Flexible installation for any kitchen, with charcoal filter included.



### CHARCOAL FILTER

Enjoy cooking and cleaner air, too. Charcoal filter removes fumes and odors that are released from foods during cooking.



### LED INTERIOR & SURFACE LIGHTING

See your cooking skills in action. Interior and cooktop LED lighting distribute bright, clear light across all cooking surfaces.

See product overviews for model-specific features.



HMV1472

### 24" 1.4 CU. FT. OVER-THE-RANGE MICROWAVE OVEN

- + Sensor cooking
- + Hidden vent
- + Two-speed fan, 300 CFM venting system
- + 10 power levels
- + 1,000-watt cooking power
- + 13.6" diameter turntable
- + LED interior and surface lighting
- + Electronic controls with LED
- + Recirculating and venting options
- + Charcoal filter included

■ Stainless – HMV1472BHS





# Dishwashers

Taking care of your social life.

## 18" DISHWASHER

### FEATURES



#### ADA COMPLIANT WITH LOW-PROFILE INSTALLATION

Small can be a very big deal. This compact unit is the perfect fit for 34" countertop heights and raised subfloors. Plus, its unique 17-4/5" width means it will slide neatly into virtually any space.

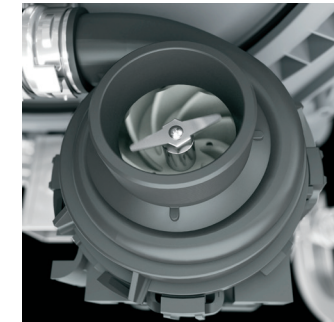

#### PIRANHA™ HARD-FOOD DISPOSER WITH REMOVABLE FILTER

Give your dishes the edge. A stainless-steel blade pulverizes food particles to ensure consistently clean items.

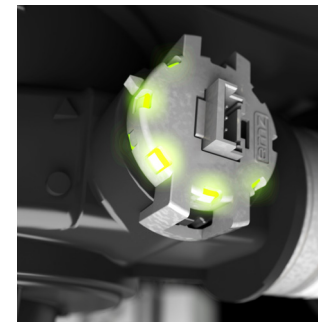

#### AUTO SENSE CYCLE

Step up your cleanup. Auto Sense adjusts cycle time based on dish soil levels and water temperature.



#### SANITIZE OPTION (NSF CERTIFIED)

Clean to the max. High-temperature rinse sanitizes dishes and eliminates 99.999% of bacteria.



QDT125SSLSS\*

#### 18" SMART BUILT-IN DISHWASHER

- + ADA compliant with low-profile installation
- + 3-level wash
- + Auto Sense cycle
- + PIRANHA hard-food disposer with removable filter
- + Sanitize option (NSF certified)
- + WiFi optional

■ Stainless – QDT125SSLSS



\*U+ Connect Module is required and sold separately. It is available for order on [geappliances.com](http://geappliances.com), part number PBX23W00Y0.





# Comfort Products

---

Create your own comfort zone.



# WINDOW UNITS

## FEATURES



### MAXIMUM COMFORT COOL

Keep your home comfortable and maximize air conditioner efficiency with three cooling and fan speeds to choose from.



### ECO MODE

Eco Mode automatically turns off the fan and compressor when the room is cool enough, reducing your utility costs.



### OPTIMAL HOME COMFORT

With availability in various BTU and pint sizes, Haier Appliances is dedicated to providing solutions for rooms of any size.



### FILTER REMINDER

Get a filter change reminder when the filter needs cleaning, so you can keep the unit performing at its best.



### ELECTRONIC THERMOSTAT WITH REMOTE

Digital controls with included remote make it easy to adjust and manage your settings from anywhere in your room.



### EASY INSTALLATION

Haier ACs come with all mounting hardware included for easy installation in the window.

See product overviews for model-specific features.

# WINDOW UNITS

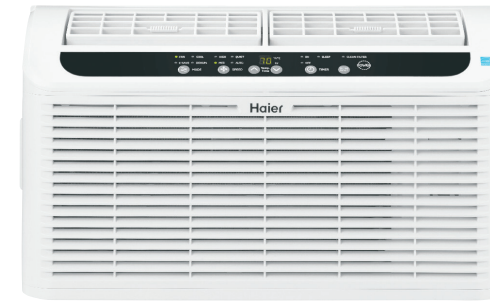

### ULTRA QUIET – ESAQ406TZ 6,200 BTU, 12.1 CEER, 115V

- + Quiet operation 42 dBA
- + Electronic digital thermostat with remote
- + 3 cooling/3 fan speeds
- + Cool, Fan, Eco and Dehumidify modes
- + 24-hour On/Off timer plus Sleep Mode
- + 4-way air direction
- + Easy-access washable filter
- + EZ Mount window installation kit

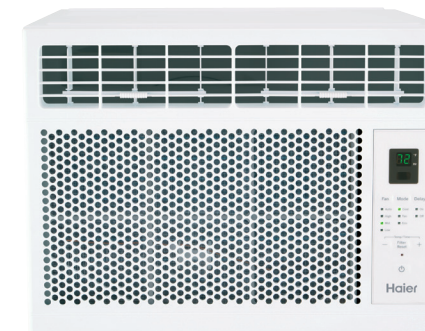

### ELECTRONIC UNIT – QHEE06AC 6,000 BTU, 11.1 CEER, 115V

- + Electronic digital thermostat with remote
- + 3 cooling/3 fan speeds
- + EZ Mount window kit with fixed chassis
- + Eco Mode feature
- + Power interruption restart
- + R32 refrigerant
- + 24-hour On/Off timer

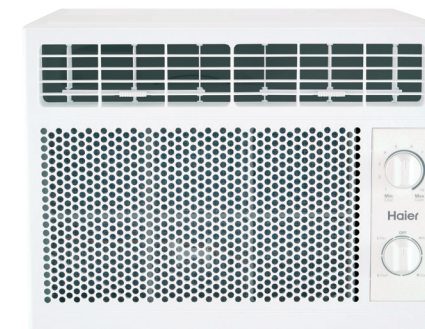

### MECHANICAL UNIT – QHEC05AC 5,050 BTU, 11.0 CEER, 115V

- + Mechanical thermostat
- + 2 cooling/2 fan speeds
- + EZ Mount window kit with fixed chassis
- + R32 refrigerant



# DUCTLESS

## MINI-SPLIT SYSTEMS



### Tempo SERIES

#### TEMPO SERIES

Ideal for areas like sunrooms and garages, these units can heat in outdoor temps down to -4°F(-20°C) and cool up to 115°F(46°C).

- + Efficiency ratings of up to 20 SEER/20 SEER2 and up to 10.5 HSPF2/9.5 HSPF2
- + 9,000 BTU, 12,000 BTU, 18,000 BTU and 24,000 BTU capacities available
- + WiFi optional. Varies based on select units. See [haierappliances.com](http://haierappliances.com) for full details.
- + Single-zone options available
- + Low ambient cooling down to -40F (with accessories) option available in 24,000, 30,000, and 36,000 BTUs



### Arctic SERIES

#### ARCTIC SINGLE AND MULTI-ZONE SERIES

Offering year-round efficiency, these cold-resistant heat pumps deliver 100% rated heating at 5°F(-15°C) and comfortably warm air down to -31F (-35C)\*.

- + High-efficiency DC inverter technology up to 30 SEER/30 SEER2 and up to 15.2 HSPF/14 HSPF2
- + Outdoor unit base pan heater included to prevent ice buildup
- + Built-in WiFi on highwall, mid-static ducted, and console single-zone units
- + Single- and multi-zone options available
- + Higher capacity single-zone units available

\*Select single-zone units



### Advanced Plus SERIES

#### ADVANCED PLUS SERIES

The ultimate combination of performance and comfort, Advanced Plus delivers efficiencies up to 23.5 SEER/23.5 SEER2 and whisper-quiet operation as low as 23dB(A).

- + Efficiency ratings of up to 23.5 SEER/23.5 SEER2 and up to 11 HSPF/10.2 HSPF2
- + Heats down to -15°F(26°C) and cools up to 115°F(46°C)
- + 9,000 BTU, 12,000 BTU, 15,000 BTU, 18,000 BTU and 24,000 BTU capacities available
- + Base pan heater included
- + WiFi compatible with adapter
- + Single-zone options available



### FlexFit SERIES

#### FLEXFIT MULTI-ZONE SERIES

Cost effective and versatile, this modular system allows for an optimal combination of ductless indoor and outdoor units.

- + Efficiency ratings up to 21 SEER/22 SEER2 and up to 11 HSPF/10 HSPF2
- + Heats down to -4°F(20°C) and cools up to 115°F(46°C)
- + Available with capacities of 24k, 36k, 42k and 48k
- + Indoor unit options include highwall, mid-static ducted, large cassette and console units
- + Built-in WiFi on highwall, mid-static ducted, and console units
- + Multi-zone options 2, 3, 4 and 5 available



TO SEE THE FULL LIST OF HAIER DUCTLESS UNITS, VISIT [HAIERAPPLIANCES.COM](http://HAIERAPPLIANCES.COM)



# LIMITED WARRANTY INFORMATION

The condensed list below is a convenient overview of the written warranties offered on various Haier appliances described in this catalog for products manufactured on or after January 1, 2006. For complete warranty details on a specific Haier model, contact your nearest Haier supplier, or call Haier Customer Care, toll-free, 1-877-337-3639.

## REFRIGERATION

### REFRIGERATORS

#### ALL HAIER MODELS

For the period of	Haier will replace
One year from the date of the original purchase	Any part in the refrigerator which fails due to a defect in materials or workmanship. During the limited one-year warranty, Haier will provide, free of charge, all labor and related service costs to replace the defective part.

### WINE & BEVERAGE CENTERS

#### ALL HAIER MODELS

For the period of	Haier will replace
One year from the date of the original purchase	Any part in the refrigerator which fails due to a defect in materials or workmanship. During the limited one-year warranty, Haier will provide, free of charge, all labor and related service costs to replace the defective part.

## COOKING

### RANGES, WALL OVEN AND HOODS

#### ALL HAIER MODELS

For the period of	Haier will replace
One year from the date of the original purchase	Any part in the cooking product which fails due to a defect in materials or workmanship. During the limited one-year warranty, Haier will provide, free of charge, all labor and related service costs to replace the defective part.
90 days from the date of the original install for glass ranges and cooktops	Haier Appliances will not cover cosmetic damage to the glass cooktop such as, but not limited to, chips, scratches, or baked-on residue not reported within 90 days of installation, or damage to the glass cooktop due to impact or misuse.

### OVER-THE-RANGE MICROWAVE OVEN

#### ALL HAIER MODELS

For the period of	Haier will choose to repair or replace
One year from the date of the original purchase	Any part of the microwave oven which fails due to a defect in materials or workmanship. During this limited one-year warranty, Haier will also provide, free of charge, all labor and related service costs to replace the defective part.

## DISHWASHERS

### DISHWASHER

#### ALL HAIER MODELS

For the period of	Haier will replace
One year from the date of the original purchase	Any part in the dishwasher which fails due to a defect in materials or workmanship. During the one-year warranty, Haier will provide, free of charge, all labor and related service costs to replace the defective part.

## COMFORT PRODUCTS

### AIR CONDITIONERS

#### WINDOW

For the period of	Haier will replace
One year from the date of the original purchase	Any part in the air conditioner which fails due to a defect in materials or workmanship. During the one-year warranty, Haier will provide, free of charge, all labor and related service costs to replace the defective part.

#### DUCTLESS

For the period of	Haier will replace
5 year limited parts warranty From the date of the original purchase	This Standard Base Limited Warranty covers all defects in workmanship or material for the mechanical and electrical parts (including the compressor) contained in the Product ("Defective Parts") for a period of 5 years from the Date of Purchase. GE Appliances will provide new or refurbished parts, or a replacement for all or part of the unit, at its sole discretion, to your licensed HVAC technician installer. This warranty also covers all defects in workmanship or material for the unit controller for a period of 1 year. The remote controller is covered by 1-year accessory warranty. The ductless system is covered by Standard Base Limited Warranty. GE Appliances will provide a new or refurbished controller, at its sole discretion.

In addition to the Standard Limited Warranty, qualify for five additional years of compressor and five additional years of parts limited warranty by registering your products within 60 days of installation. See full warranty details in installation manual.

# ACCESSIBILITY REQUIREMENTS

## REFRIGERATORS

[Uniform Federal Accessibility Standards \(UFAS\)](#)

### TOP-FREEZERS AND SIDE-BY-SIDES

Regulation #/Description:

4.2.6 Side Reach—If the clear floor space allows parallel approach by a person in a wheelchair, the maximum high side reach allowed shall be 54" and the low side reach shall be no less than 9" above the floor.

4.27.4 Operation—Controls and operating mechanisms shall be operable with one hand and shall not require tight grasping, pinching, or twisting of the wrist. The force required to activate controls shall be no greater than 5lbf (222N).

4.34.6.8 Refrigerators/Freezers—Refrigerator/freezers shall comply with 4.34.6.3. Provision shall be made for refrigerators which are: (1) Of the vertical side-by-side refrigerator/freezer type; OR (2) Of the over-and-under type and meet the following requirements: (a) Have at least 50 percent of the freezer space below 54" above the floor. (b) Have 100 percent of the refrigerator space and controls below 54".

### Americans With Disabilities Act (ADA) Requirements

#### TOP-FREEZERS AND FRENCH-DOOR BOTTOM-FREEZERS WITH EXTERNAL DISPENSER CONTROL

Regulation #/Description:

804.6.2 & 804.6.6—Operable parts shall be operable with one hand and shall not require tight grasping, pinching, or twisting of the wrist. The force required to activate operable parts shall be 5lbf max.

309.4 EXCEPTION: Appliance door and door latching devices do not need to comply with requirement. 804.6.2. Refrigerators/freezers shall have at least 50 percent of the freezer space 54" max. above the floor. The clear floor or ground space shall be positioned for a parallel approach to the space dedicated to a refrigerator/freezer with the centerline of the clear floor or ground space offset 24" maximum from the centerline of the dedicated space. Preference for side-by-side and top-mount eliminated; bottom-mount now acceptable 804.6.6.

[The following appliance categories meet criteria for both the Uniform Federal Accessibility Standards \(UFAS\) and the Americans with Disabilities Act \(ADA\) requirements.](#)

## WALL OVENS

### SINGLE SELF-CLEAN OVENS

Regulation #/Description:

4.2.5—maximum high forward reach for controls and operating mechanisms is 48", minimum low forward reach is 15".

4.27.4—controls and operating mechanisms must be operable with one hand and shall not require tight grasping, pinching, or twisting of the wrist. The force required to activate controls shall be no more than 5lbf.

4.34.6.7—ovens shall have controls on front panels; they may be located on either side of the door.

### FREE-STANDING RANGES

#### ELECTRIC AND GAS

Regulation #/Description:

4.2.5—maximum high forward reach for controls and operating mechanisms is 48", minimum low forward reach is 15".

4.27.4—controls and operating mechanisms must be operable with one hand and shall not require tight grasping, pinching, or twisting of the wrist. The force required to activate controls shall be no more than 5lbf.

4.34.6.6—if ovens or cooktops have knee spaces underneath then they shall

be insulated or otherwise protected on the exposed surfaces to prevent burns, abrasions, or electrical shock. The location of controls for ranges and cooktops shall not require reaching across burners.

## MICROWAVE OVENS

### BUILT-IN CONFIGURATION

Regulation #/Description:

4.2.5—maximum high forward reach for controls and operating mechanisms is 48", minimum low forward reach is 15".

4.27.4—controls and operating mechanisms must be operable with one hand and shall not require tight grasping, pinching, or twisting of the wrist. The force required to activate controls shall be no more than 5lbf.

## DISHWASHERS

Regulation #/Description:

4.2.5—maximum high forward reach for controls and operating mechanisms is 48", minimum low forward reach is 15".

4.27.4—controls and operating mechanisms must be operable with one hand and shall not require tight grasping, pinching, or twisting of the wrist. The force required to activate controls shall be no more than 5lbf.

4.34.6.9—all rack space shall be accessible from the front of the machine for loading and unloading dishes.

## ROOM AIR CONDITIONERS

Regulation #/ Description:

4.2.5—maximum high forward reach for controls and operating mechanisms is 48", minimum low forward reach is 15".

4.27.4—controls and operating mechanisms must be operable with one hand and shall not require tight grasping, pinching, or twisting of the wrist. The force required to activate controls shall be no more than 5lbf.

\*See written warranty for complete details.



# REFRIGERATION

## FRENCH-DOOR REFRIGERATORS

	QHE16HYPPFS	QJS15HYRFS	
ENERGY STAR® certified	•		
Quad-Door model	•		
Sabbath mode capable	•	•	
<b>CAPACITY</b>			
Total (cu. ft.)	16.8	14.5	
Fresh food (cu. ft.)	11.2	9.37	
Freezer (cu. ft.)	5.56	5.14	
<b>FRESH-FOOD FEATURES</b>			
External controls with temp. display and child lock	•	•	
Door alarm	•	•	
Upfront temperature controls	•		
Quick Cool/Turbo Cool	•	•	
Cabinet shelves	Shelves	3	4
	Adjustable	2	1
	Full-width	3	4
Adjustable-humidity drawers		1	
Full-width drawer		•	
Crisper drawers	2		
Clear encapsulated door bins	6 adjustable	•	
Lighting	•	LED	
<b>FREEZER FEATURES</b>			
Lighting		LED	
Quick Freeze setting	•	•	
Adaptive Defrost technology		•	
Full-width, full-extension storage drawer	4	2	
Slide-out tray(s)	2		
<b>EXTERIOR</b>			
Color(s) available	Fingerprint resistant stainless	Fingerprint resistant stainless	
	Counter-depth configuration	•	
	Handle design	Recessed	Recessed
Door design	Curved	Flat	
Textured steel case color	Door only	Case only (light gray)	
Exterior material	Stainless	Stainless	
Door stops	•	•	
Adjustable rollers		2	
<b>WEIGHTS &amp; DIMENSIONS</b>			
Height to top of door (in.) <b>A</b>	71-3/16	69-7/8	
Height to top of hinge (in.) <b>B</b>	71-3/16	69	
Height to top of case (in.) <b>C</b>	70-11/16	68	
Depth (in.)	26-1/2	26-9/16	
Depth without door (in.) <b>D</b>	22-1/2	24-1/4	
Depth less door handle (in.) <b>E</b>	26-3/16	26-9/16	
Depth with fresh-food door open 90° (in.) <b>G</b>	39-7/8	38	
Width (in.) <b>H</b>	32-3/4	27-3/4	
Width with door open 90° with door handle (in.) <b>I</b>	34-7/8	29-5/8	
Air clearances (in.)	Each side	0	1/8
	Top	1	1/8
	Back	2	2
Approximate shipping wt. (lbs.)	249	225	
Net weight (lbs.)	232	201	
<b>POWER/RATINGS</b>			
Power/Ratings	115V; 60 Hz; 15 or 20 Amps	120V; 60 Hz; 15 Amps	

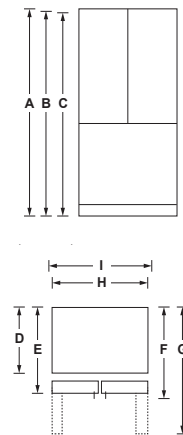

## BOTTOM-FREEZER REFRIGERATORS

	HRB15N3BGS	
ENERGY STAR® certified	•	
Sabbath mode capable	•	
<b>CAPACITY</b>		
Total (cu. ft.)	15.1	
Fresh food (cu. ft.)	11.2	
Freezer (cu. ft.)	3.9	
<b>FRESH-FOOD FEATURES</b>		
External controls with child lock	•	
Door alarm	•	
Quick Cool setting	•	
Cabinet shelves	Shelves	3
	Adjustable	2
	Full-width	3
Multi-level drawers	•	
Full-width drawer	2	
Crisper drawers	1	
Clear encapsulated door bins	3 full-width fixed	
LED lighting	•	
<b>FREEZER FEATURES</b>		
Adaptive Defrost technology	•	
Quick Freeze	•	
Freezer storage drawer(s)	3	
Slide-out tray(s)		
<b>EXTERIOR</b>		
Color(s) available	Stainless	
Counter-depth configuration		
Handle design	Recessed	
Door design	Curved	
Textured steel case	Door only	
Exterior material	Stainless	
Door stops	•	
Reversible doors	•	
Right or left door opening	Reversible	
Adjustable leveling legs	•	
<b>WEIGHTS &amp; DIMENSIONS</b>		
Height to top of door (in.) <b>A</b>	67-7/8	
Height to top of hinge (in.) <b>B</b>	67-7/8	
Height to top of case (in.) <b>C</b>	67-5/8	
Case depth without door (in.) <b>D</b>	23-5/8	
Depth less door handle (in.) <b>E</b>	26-3/4	
Depth with door handle (in.) <b>F</b>	26-3/4	
Depth with fresh-food door open 90° (in.) <b>G</b>	52-4/5	
Width (in.) <b>H</b>	27-1/2	
Width with door open 90° with door handle (in.) <b>I</b>	29-1/8	
Air clearances (in.)	Each side	1
	Top	1
	Back	2
Approximate shipping wt. (lbs.)	192	
Net weight (lbs.)	174	
<b>POWER/RATINGS</b>		
Power/Ratings	115V; 60 Hz; 15 or 20 Amps	

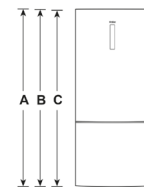

## TOP-FREEZER REFRIGERATORS

	HA10TG21SS HA10TG21SW HA10TG21SB	
<b>CAPACITY</b>		
Total (cu. ft.)	9.8	
Fresh food (cu. ft.)	7.4	
Freezer (cu. ft.)	2.4	
<b>FRESH-FOOD FEATURES</b>		
Cabinet shelves	Shelves	3
	Adjustable	2
Drawers	1 humidity-controlled crisper	
Door shelves	4 (2 full-width, 2 half-width)	
Interior lighting	LED	
<b>FREEZER FEATURES</b>		
Spillproof freezer floor	•	
Freezer compartment shelves	1 full-width adjustable glass	
Fixed door bins	2 full-width	
<b>EXTERIOR</b>		
Color(s) available	Stainless, White, Black	
Handle color	Black*	
Handle design	Pocket	
Door design	Curved	
Textured steel door and case	Door only	
Reversible doors	•	
<b>WEIGHTS &amp; DIMENSIONS</b>		
Height to top of hinge (in.)	59-1/2	
Height to top of case (in.)	58	
Depth without door (in.)	22-3/8	
Depth less door handle (in.)	25-1/4	
Depth (in.)	25-1/4	
Depth with fresh-food door open 90° (in.)	47-1/4	
Width (in.)	23-5/8	
Width with door open 90° with door handle (in.)	23-5/8	
Air clearances (in.)	Each side	1
	Top	1
	Back	2
Approx. shipping wt. (lbs.)	132	
Net weight (lbs.)	119	
<b>POWER/RATINGS</b>		
Power/Ratings	120V; 60 Hz; 15 Amps	

\*White unit has color-matched handle.

## BEVERAGE CENTER

	HEBF100BXS	
<b>CERTIFICATIONS &amp; APPROVALS</b>		
ADA compliant	•	
<b>CAPACITY</b>		
Can capacity	150	
<b>FEATURES</b>		
Thermostat	Adjustable	
Security lock	•	
Thermostat	•	
Temperature range	39°-55° F	
Interior shelves	4 full-width	
Interior lighting	LED	
Leveling legs	Adjustable	
<b>EXTERIOR</b>		
Door	Reversible	
Door appearance	Glass	
Handle	Recessed	
<b>WEIGHTS &amp; DIMENSIONS</b>		
Width (in.)	20-1/2	
Height (in.) (including hinge)	31-3/8	
Depth (in.)	21-1/4	
Depth with door open 90° (in.)	43	
Air clearances (in.)	Each side	5
	Back	2
	Top	2
Net weight (lbs.)	67	
Approx. shipping weight (lbs.)	72	
<b>POWER/RATINGS</b>		
Electrical requirements	115V, 60Hz UL	

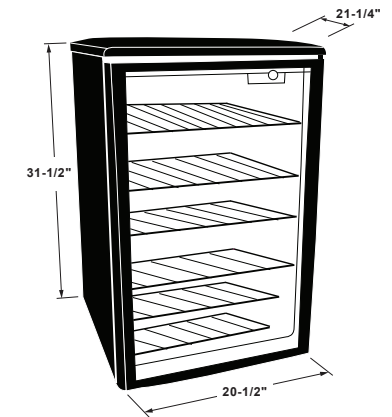

## WINE CENTER

	QWR04DG	
<b>CERTIFICATIONS &amp; APPROVALS</b>		
ADA compliant	No	
<b>CAPACITY</b>		
Total (cubic feet)	4	
Bottle capacity	40	
<b>FEATURES</b>		
Dual Temperature Zone	Yes	
Security lock	No	
Temperature Range	41° to 61° F	
Interior Shelves	3 full, 1 half wood	
Interior Lighting	Recessed LED	
Leveling Legs	2	
Door Alarm	Audible	
<b>EXTERIOR</b>		
Reversible Door	Yes	
Cabinet	Black	
Door Appearance	Glass door	
Handle	Integrated	
Controls	Electronic	
<b>WEIGHTS &amp; DIMENSIONS</b>		
Width (in.)	19-3/5	
Height (in.) (including hinge)	32-3/10	
Depth (in.)	23	
Depth with door open 90° (in.)	41-1/5	
Air clearances (in.)	Each side	1
	Back	2
	Top	1
Net weight (lbs.)	87	
Approx. shipping weight (lbs.)	95	
<b>POWER/RATINGS</b>		
Electrical requirements	115V, 60Hz UL	



# COOKING

## 24" FREE-STANDING GAS RANGES

QGAS740RMSS

FEATURES	
Capacity (upper/lower)	2.9
Cleaning system	Steam Clean
Cooking technology	Fan Convection
Compliance	ADA compliant; California Prop 65; UL; CSA
CONTROLS	
Mechanical oven controls	•
Digital temperature display	•
Electronic clock & timer	•
Ignition	Electronic
COOKTOP	
Burner—left front (000's BTU) Nat./LP	
Burner—left rear (000's BTU) Nat./LP	9,500 for both left burners
Burner—right front (000's BTU) Nat./LP	15,000
Burner—right rear (000's BTU) Nat./LP	5,000
Cooktop burners	Sealed
Deep-recessed cooktop	•
OVEN	
In-oven broiling	•
Probe mode	
Interior oven light	1
Oven racks	2
APPEARANCE	
Backguard (included accessory)	Stainless
Color appearance	Stainless
Grates	Continuous
Grate material	Cast iron
Handle color	Stainless
Knobs—color	Stainless
Oven interior	Black
WEIGHTS & DIMENSIONS	
Approx. shipping wt. (lbs.)	121
Net weight (lbs.)	108
Overall oven interior dimensions (HxWxD in inches)	19 x 15-3/8 x 17-1/8
Overall dimensions (HxWxD in inches)	41 x 24 x 28-1/8
POWER/RATINGS	
Bake (000's BTU) Nat./LP	13,000/13,000
Broil (000's BTU) Nat./LP	13,000/13,000
Gas range electrical rating	120V; 60Hz
LP conversion kit (included)	•

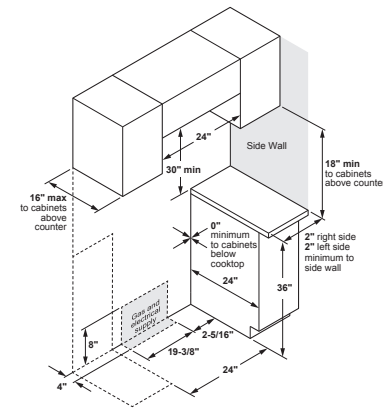
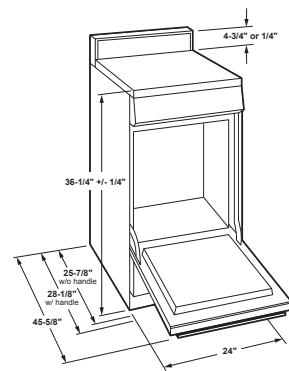

## 24" FREE-STANDING ELECTRIC RANGES

QAS740RMSS

FEATURES	
Capacity (cu. ft.) upper/lower	2.9
Cleaning system	Steam Clean
Cooking technology	Fan Convection
Compliance	ADA compliant; California Prop 65; UL
CONTROLS	
Mechanical oven controls	•
Digital temperature display	•
Hot surface lights	•
COOKTOP	
Element—left front	6" 1,200W
Element—left rear	8" 2,000W
Element—right front	8" 2,200W
Element—right rear	6" 1,200W
OVEN	
Interior oven light	1
Oven racks	2
Bake element	Hidden
Broil element	4-pass
APPEARANCE	
Backguard (included accessory)	Stainless
Ceramic-glass cooktop	Black
Color appearance	Stainless
Handle color	Stainless
Knobs—color	Stainless
Oven interior	Black
WEIGHTS & DIMENSIONS	
Approx. shipping wt. (lbs.)	136
Net weight (lbs.)	123
Overall oven interior dimensions (HxWxD in inches)	19 x 15-3/8 x 17-1/8
Overall dimensions (HxWxD in inches)	40 x 24 x 28-1/8
POWER/RATINGS	
Bake wattage	2,700W
Broil wattage	3,000W
Electrical rating	208/240V; 60Hz

## 24" BUILT-IN SINGLE OVEN

HCW2360AES

FEATURES & CONTROLS	
Capacity (cu. ft.)	2.0
Oven	Self-clean
Cleaning time	Variable
Compliance	California Prop 65; UL
Automatic self-clean oven door lock	•
True European Convection	•
Control type	Electronic touch
Temperature display	•
Audible preheat signal	•
Electronic clock and kitchen timer	•
Control lock capability	•
Oven light	•
Oven racks	2
Rack positions	4
APPEARANCE	
Color appearance	Stainless
Frameless oven doors	Stainless
Oven door with window	•
Handle color	Stainless
WEIGHTS & DIMENSIONS	
Approx. shipping wt. (lbs.)	82
Net weight (lbs.)	72
Oven cabinet width required (in.)	24
Overall dimensions (WxHxD in inches)	23-3/8 x 23-3/8 x 24-1/8
Overall oven interior dimensions (WxHxD in inches)	17-21/25 x 13-7/25 x 16-14/25
Depth with door open 90° (in)	42-1/4
POWER/RATINGS	
KW rating @	240V 3.1
	208V 2.35
	240V 13.3
Amps @	208V 11.7
Broiler wattage	2,100 W
Bake wattage	1,100 W
Convection wattage	2,500 W

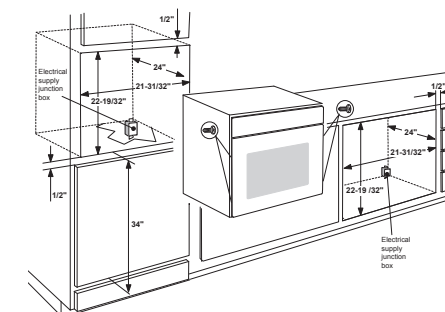
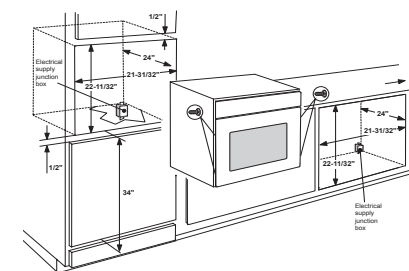

## OVER-THE-RANGE MICROWAVE OVENS

HMV1472BHS

FEATURES	
Capacity (cu. ft.)	1.4
Watts—microwave (IEC-705 test procedure)	1,000 W
Cooking mode	Sensor
Factory-set recirculation	•
Compliance	California Prop 65; UL; CSA
CONTROLS	
Convenience controls	Defrost weight/time • Popcorn •
Sensor controls	Potato • Frozen pizza • Frozen vegetable • Dinner • Rice • Breakfast • Bacon •
Sensor reheat	Beverage • Dinner plate • Pizza • Soup/sauce • Casserole •
Controls touchpad	Add 30 seconds • Control lockout • Electronic touch controls •
OVEN	
Interior/exterior lighting	LED
Cooktop lighting	LED (High/Low/Off)
Turntable (On/ Off)	•
Turntable diameter (in.)	13.57
APPEARANCE	
Color appearance	Stainless with black
Case color	Black
Handle design	Recessed
Oven interior	Gray painted diamond cut
Touchpad	Black with gray
WEIGHTS & DIMENSIONS	
Approx. shipping wt. (lbs.)	63
Net weight (lbs.)	55
Overall dimensions (HxWxD in inches)	17-1/64 x 23-55/64 x 16-3/16
Overall oven interior dimensions (HxWxD in inches)	15-5/8 x 10-1/8 x 15-3/16
POWER/RATINGS	
Exhaust vent fan	300 CFM
Input Volt/Hertz	120V/60Hz
Input Amps/Watts (max.)	15/1,500

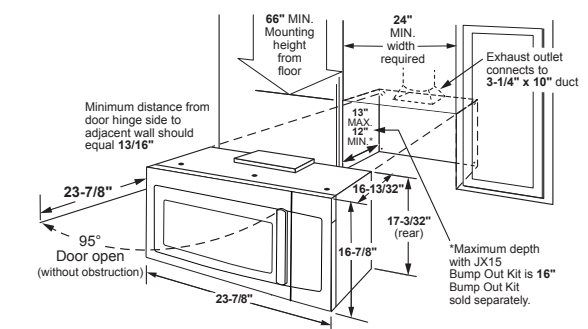



# DISHWASHERS

## 18" BUILT-IN DISHWASHER

QDT125SSLSS	
ADA compliant	•
<b>FEATURES</b>	
Style	Built-in
Tub and door liner	Stainless steel
Control type	Fully integrated electronic, top controls, 4 pushbuttons
Dishwasher control features	Start/Reset pad, 2-digit display cycle countdown, 1 "Clean" cycle progress indicator, audible end-of-cycle signal, last cycle memory
Wash system	3-level standard
Wash system features	Dual pumps and motor drain hose
Wash arms	2 lower middle with upper nozzle
Water filtration system	3-stage manual-clean filtration
Dispenser	Rinse aid with indicator, adjustment and LED
Number of cycles	3
Dishwasher cycles	Heavy Wash/Light Wash/Autosense
Number of options	5
Dishwasher options	Delay start 1-12 hr. with countdown
Rack features	Standard silverware basket, 1 plastic utility shelf—upper
Racking system	Nylon gray
Number of place settings	Up to 8
Upper rack	Nylon
Lower rack	Nylon
Dishwasher drying features	Condensate
Leveling system	Leveling legs
Latch	Center pull
Exterior style	18" wide
<b>ECONOMICAL/QUIET</b>	
Quiet package	47 dBA
Quiet features	Sealed toe kick, Tub collar trim
Motor type	Standard
Outer wrap	U-blanket
Door insulation	Insulation mastic
<b>APPEARANCE</b>	
Color appearance	Stainless
Door style	Stainless steel full-length flat door
Handle color	Color matched
Handle design	Pocket handle
<b>WEIGHTS &amp; DIMENSIONS</b>	
Approx. ship. wt. (lbs.)	85
Net weight (lbs.)	72
Overall height (in.)	32-3/8
Height w/legs retracted—min. ht. (in.)	32-3/8
Height w/legs extended—max. ht. (in.)	35
Overall depth (in.)	22-1/2
Overall width (in.)	18
<b>POWER/RATINGS</b>	
Calrod heater watts	1,100
Electrical requirements	120V; 60Hz; 8.9A

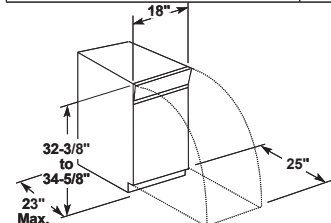

# COMFORT PRODUCTS

## ULTRA-QUIET ROOM AIR CONDITIONER

ESAQ406TZ	
Claims & Certification	ENERGY STAR® certified
<b>PERFORMANCE</b>	
Area to Cool (sq. ft.)	151-250
Cooling BTUH	6200
Dehumidification (pts./hr.)	1.5
CEER rating	12.1
Cooling - watts	490
Volts/Hertz	115/60
Plug capacity (Volts/Amps)	120/10
Cooling - Rated Cooling Amps AHAM	4.4
Air Flow Volume CFM High/Medium/Low	175/135
<b>ECONOMICAL / QUIET</b>	
Energy Saver	•
<b>APPEARANCE</b>	
Installation	EZ Mount
<b>FEATURES</b>	
Chassis type	Fixed
Fan speed selections	3 Cooling, 3 Fan
Easy-access washable filter	•
Air discharge	4-way
Vent/air exchange exhaust	Top
Remote control	Yes
Adjustable thermostat	Electronic
Auto restart	Yes
Digital time temp, display	Yes
Power cord length (ft.)	6
Delay timer	24-Hour On/Off
Check Filter reminder	Yes
Sleep mode	Yes
<b>WEIGHTS &amp; DIMENSIONS</b>	
Approximate shipping weight (lbs.)	69.3
Min./Max. window opening width (in.)	26-9/16 / 39-1/4
Minimum window opening height (in.)	13-3/8
Net weight (lbs)	56
Overall depth (in.)	18-1/8
Overall height (in.)	12-7/16
Overall width (in.)	21-1/4

## WALL OUTLETS

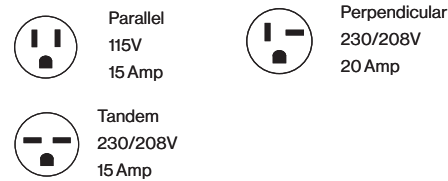

## Wall outlets

All wiring, including installation of receptacle, must be made in accordance with local electrical codes and regulations. Electrical outlet should be in reach of line cord.

Note: Aluminum building wiring may pose special problems—consult a qualified electrician.

## WINDOW ROOM AIR CONDITIONERS

QHEC05AC QHEE06AC		
Claims & Certification	UL, cUL, AHAM	
<b>PERFORMANCE</b>		
BTUH/HR rating	5,050	6,000
CEER rating (Min.)	11.0	11.1
Voltage /Hertz	115	115
Cooling Amps AHAM	4.1	4.9
Cooling - Watts	455	535
Airflow (cfm) Roomside (hi/low)	143/122	139/109
Dehumidification (pts./hr.)	1.0	1.4
Unit type	Cool only	Cool only
Variable air discharge	2-way	4-way adjustable
Air discharge	Top	Top
Refrigerant type	R32	R32
Power cord length (min.)(feet)	72" minimum	72" minimum
<b>ECONOMICAL / QUIET</b>		
Eco Mode	No	Yes
<b>APPEARANCE</b>		
Color appearance	White	White
Installation	EZ Mount	EZ Mount
Window curtain	Yes	Yes
<b>FEATURES</b>		
Chassis type	Fixed	Fixed
Delay timer	No	24-hour On/Off
Fan speed selections	2/2	3/3
Easy-access washable filter	Yes	Yes
Remote control	No	Yes
Adjustable thermostat	Mechanical	Electronic
Sleep mode	No	No
<b>WEIGHTS &amp; DIMENSIONS</b>		
Approximate shipping weight (lbs.)	41.2	43.7
Min./Max. window opening width (in.)	21-7/8 - 36	21-7/8 - 36
Minimum window opening height (in.)	13-3/8	13-3/8
Net weight (lbs.)	35.93	38.92
Overall depth (in.)	15	15
Overall height (in.)	12-9/16	12-9/16
Overall width (in.)	16-7/16	16-7/16

# NOMENCLATURES

## REFRIGERATION

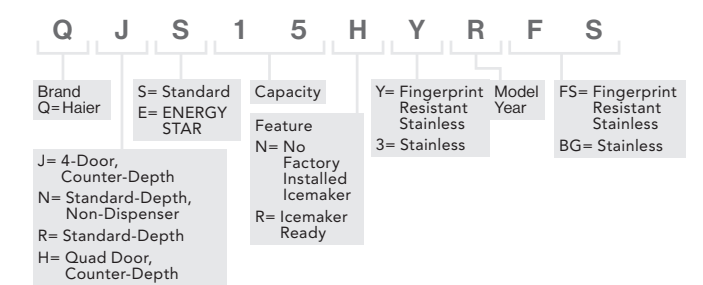

## COOKING

### RANGES

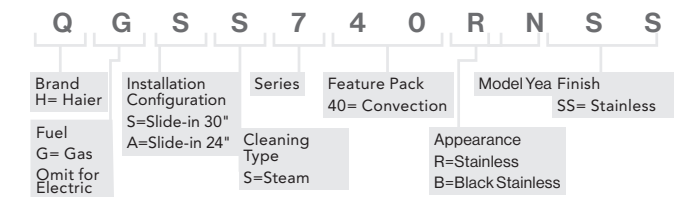

## BUILT-IN COOKING & VENTILATION

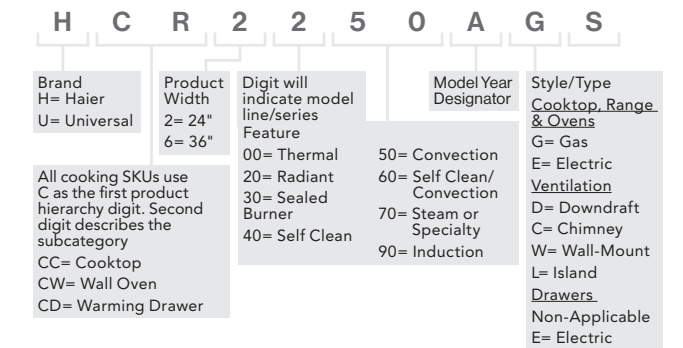

## OVER-THE-RANGE MICROWAVE

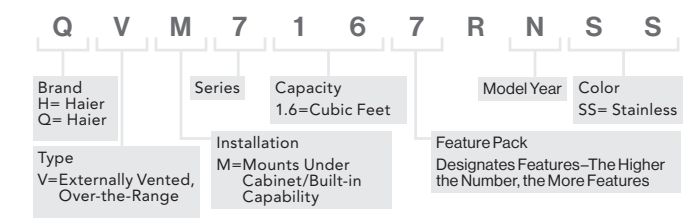

## DISHWASHER

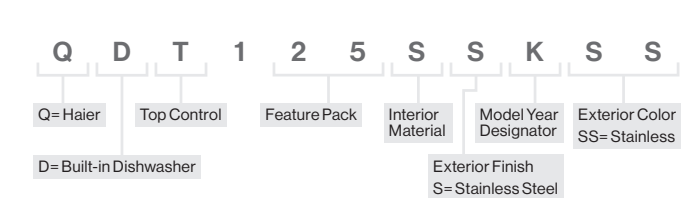



# PARTS AND ACCESSORIES

## STAINLESS STEEL MAINTENANCE

Cerama Bryte® Stainless Steel Wipes, 35-count	WX10X10004
Cerama Bryte Stainless Steel Cleaner & Polisher, 16-oz.	PM10X311
Cerama Bryte Microfiber Cleaning Cloths, 2-pack	WX10X307
Cerama Bryte Stainless Steel Polish Kit Includes 8-oz cleaner/polisher + microfiber cloth	WX10X33765

## REFRIGERATION

GE icemaker kit	IM6D
GE premium replacement water filter	XWF
Ice machine cleaner	WX08X42870
Freezer utility shelf	WR71X2086
Braided Pex icemaker water line, 12' length	WX08X10012
Pex icemaker water line, 8' length	WX08X10006
Pex icemaker water line, 15' length	WX08X10015
Appliance brush set, 2 brushes	PM14X10056
Cerama Bryte Refrigerator Cleaner	WX10X10206
40-watt appliance light bulbs, 2-pack	40A15-2PK

## COOKING

Cerama Bryte Complete Cooktop Kit	WX10X10020
Cerama Bryte Gas Grate Cleaning Kit	WX10X10021
Universal 4' gas range installation kit	PM15X103
Cerama Bryte Cooktop Scraper	WX10X302
Cerama Bryte Microfiber Cleaning Cloths, 2-pack	wx10x307
Cerama Bryte Burnt-On Grease Remover	WX10X320
Cerama Bryte Cleaning Pads, 4-pack	WX10X350
Cerama Bryte Touchups Spray	WX10X391
Broiler pan/rack set (12-3/4" x 16-1/2")	WB48X10056
4' 4-wire 40-amp electrical range cord	WX09X10035
4' 3-wire 40-amp electrical range cord	WX09X10006
Cerama Bryte Glass-Ceramic Cooktop Cleaner	WX10X300
Cerama Bryte Ceramic Cooktop Scraper and Pad	PM10X304

## MICROWAVE OVENS

Cerama Bryte Appliance Cleaner	WX10X392
--------------------------------	----------

## DISHWASHERS

Universal dishwasher installation kit	PM28X329
Universal 12' dishwasher connector kit with adapter	WX28X327
Dishwasher power cord, 5' 4"	WX09X70910
Dishwasher power cord, 7' 9"	WX09X70911
Dishwasher bracket kit for non-wooden countertops	WX13X10001
10' dishwasher drain hose	WX28X321
Finish® Dishwasher Cleaner 8.45 oz. bottle	WX10X10209
Finish Jet-Dry® Rinse Aid 16 oz. bottle	WX10X10210
Finish Dishwasher Detergent Booster 14 oz. canister	WX10X10022

Cerama Bryte is a registered trademark of Cerama Bryte, Inc. Finish is a registered trademark of Reckitt Benckiser Group.

Haier has a policy of continuous improvement of its products and reserves the right to change materials and specifications without notice.



## Warranty Information

All parts and accessories have a limited one-year warranty, with the exception of water filters, which have a 30-day warranty.

### Limited One-Year Warranty

If your Haier part fails because of a manufacturing defect within one year from the date of original purchase, we will provide a new or, at our option, rebuilt part without charge. Return the defective part to the vendor from whom it was purchased with a copy of the "proof of purchase." If the part is defective it will be exchanged. This warranty does not cover parts which are improperly installed, damaged, abused or used for other than the intended purpose. It does not include cost of returning the part to the vendor from which it was purchased, labor to remove, install or diagnose the failure, parts used in commercial applications, incidental or consequential damage caused by possible defects with the parts.



French-Door Refrigerator: HRF15N3AGS  
Dishwasher: QDT125SSLSS  
Over-the-Range Microwave Oven: HMV1472BH  
Free-Standing Range: QAS740RMSS

# Small spaces can provide big benefits.

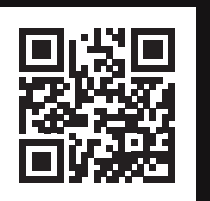

SCAN FOR  
SMALL SPACE  
SOLUTIONS

Haier's suite of compact appliances offers the technology and worldly appeal that tenants expect to find in the city. And each product is backed by GE Appliances' robust customer support, factory-trained servicers and nationwide distribution network. That means you can expect fewer service calls, thanks to the #1 Brand of Major Appliances 13 years in a row.\*

See the complete suite of small appliances at [geappliances.com/pro](https://geappliances.com/pro).

# Haier

Born for the city.

\*Euromonitor 2021