



GE APPLIANCES
a Haier company



BRANDS NOMENCLATURE

MONOGRAM

CAFÉ



Profile™

Haier

Hotpoint.

AIR&WATER
SOLUTIONS

PROFESSIONAL RANGES AND RANGETOPS

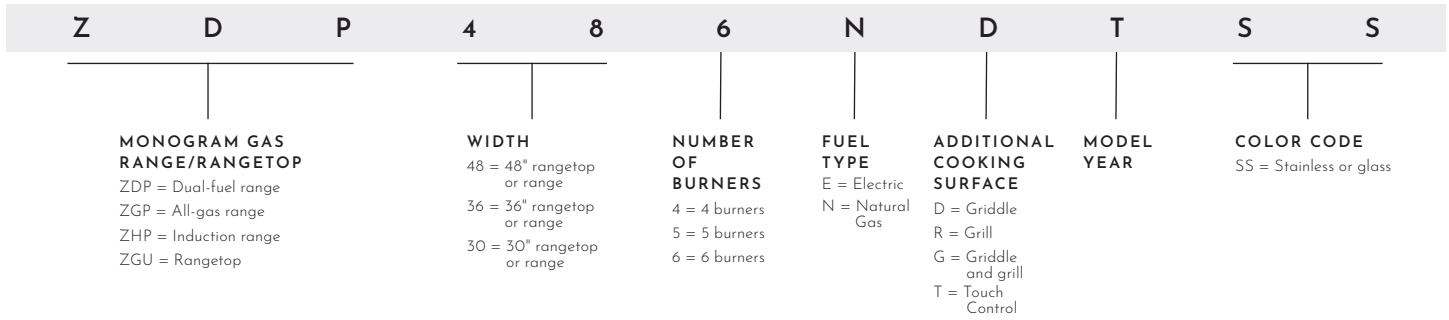

INDUCTION AND GAS COOKTOPS

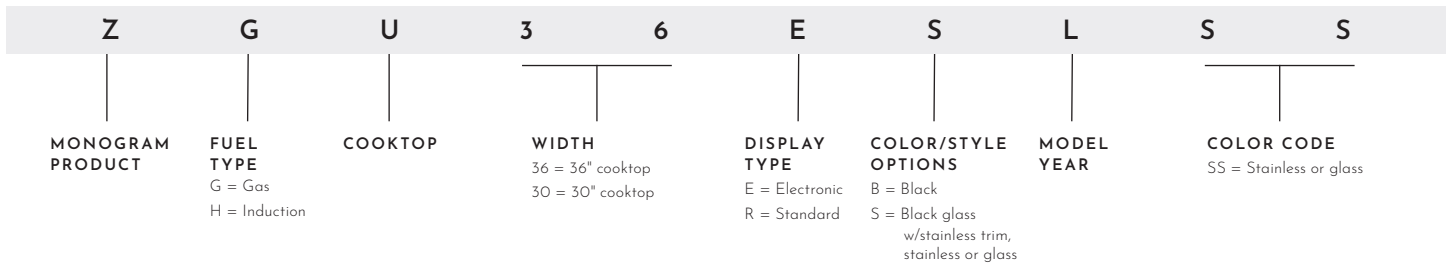

HEARTH OVENS

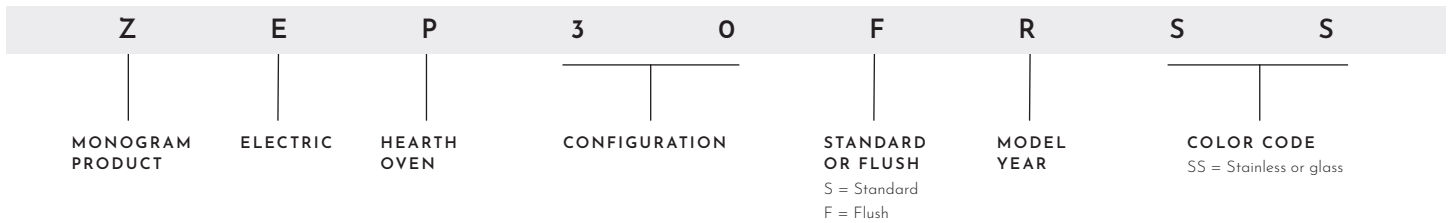

WALL OVENS

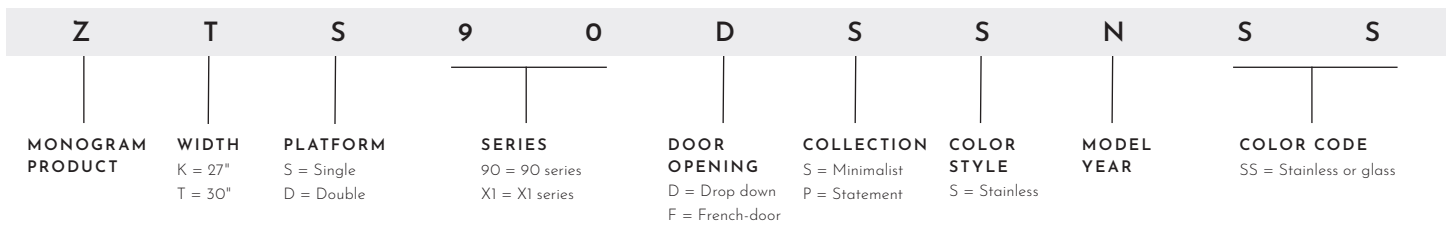

STEAM OVENS

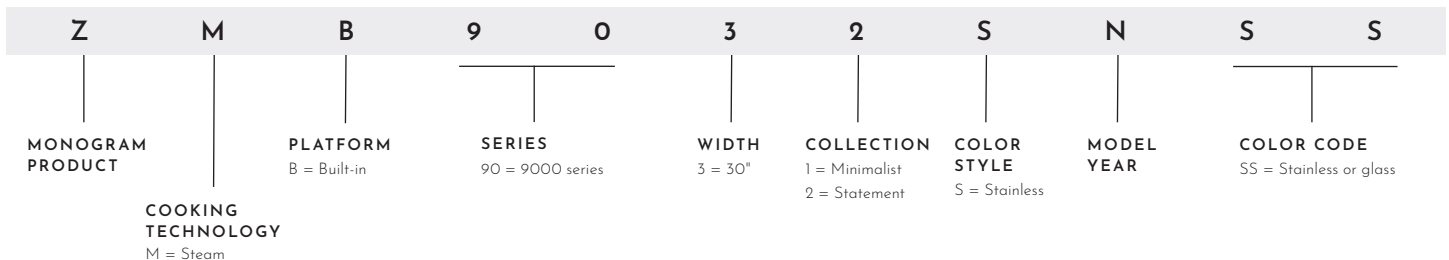

ADVANTIUM® OVENS

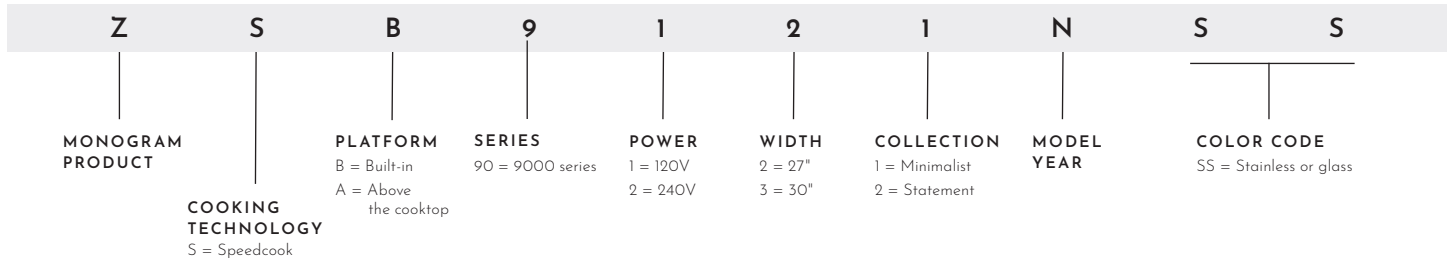

MICROWAVE OVENS

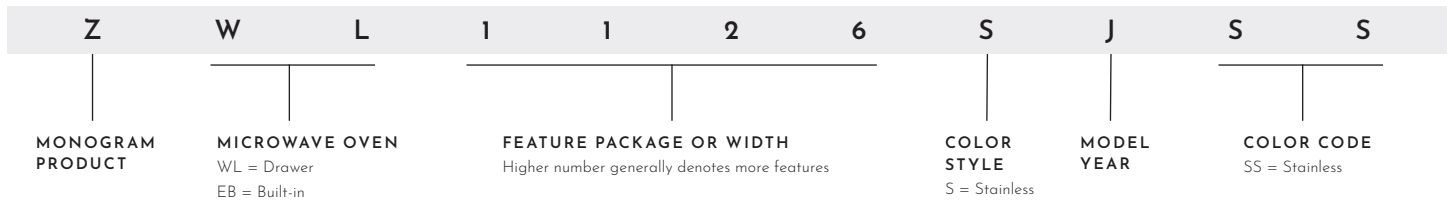

WARMING & STORAGE DRAWERS



PROFESSIONAL VENTILATION

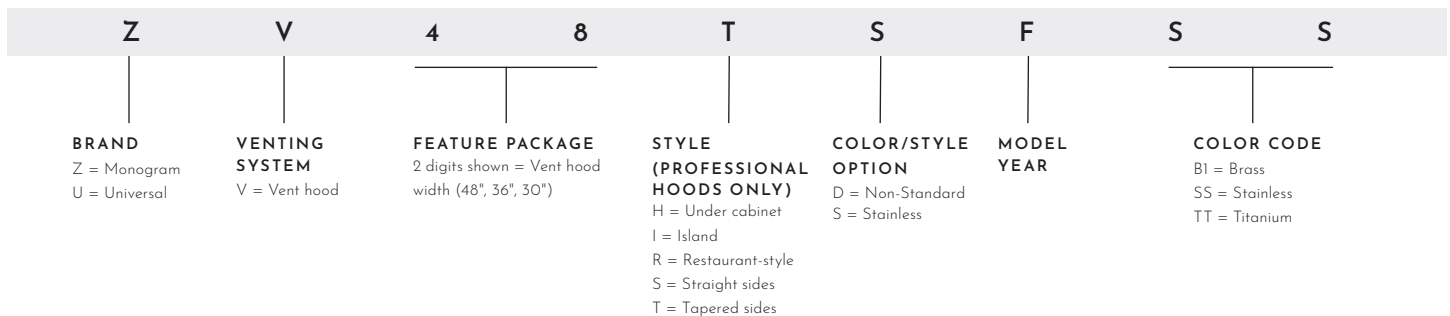

VENTILATION

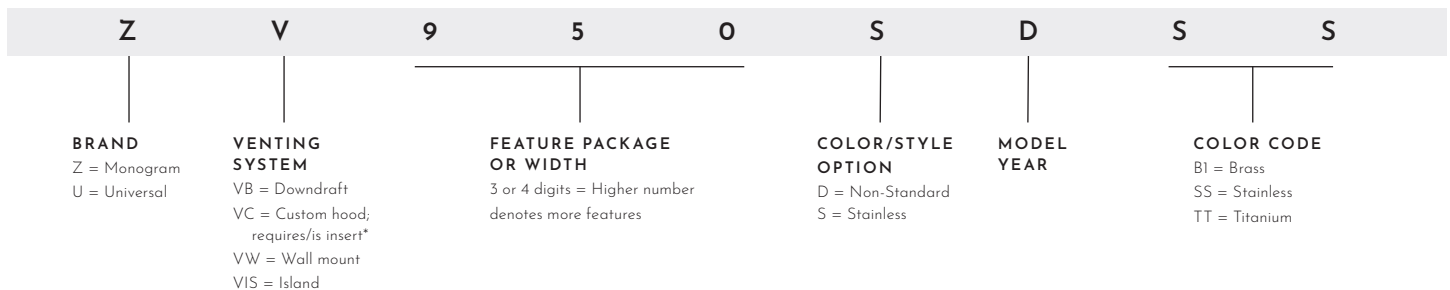

*Please review model details to determine if SKU is a custom insert, or hood requiring custom insert.

NOMENCLATURE



REFRIGERATOR & FREEZER COLUMNS

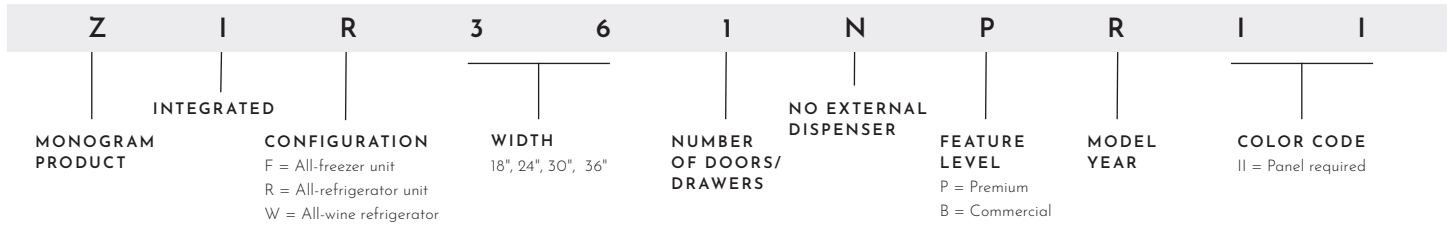

INTEGRATED BOTTOM FREEZERS, REFRIGERATORS, & WINE SOMMELIERS

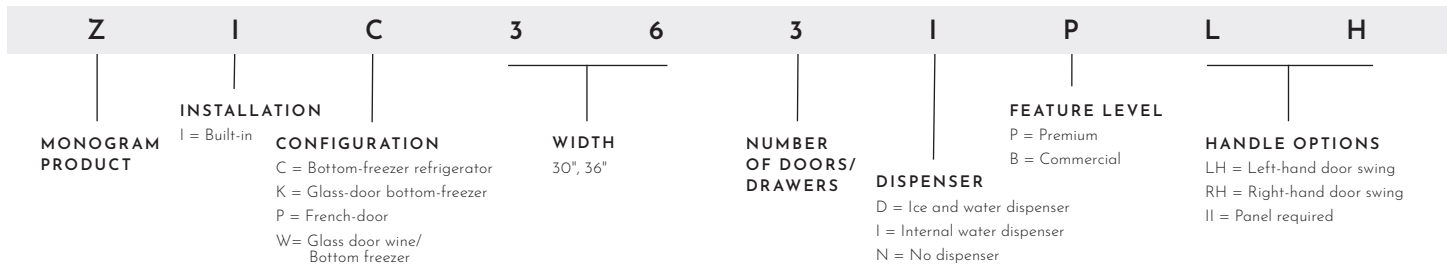

BUILT-IN SIDE-BY-SIDE REFRIGERATORS

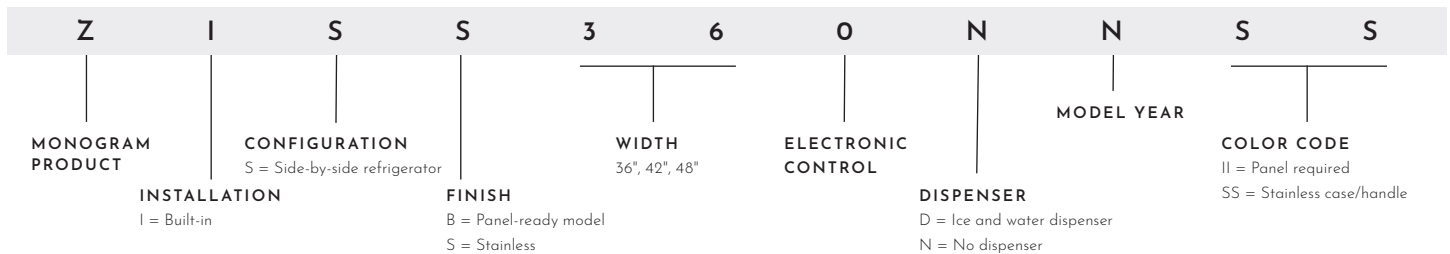

FREE-STANDING REFRIGERATORS



UNDERCOUNTER REFRIGERATORS

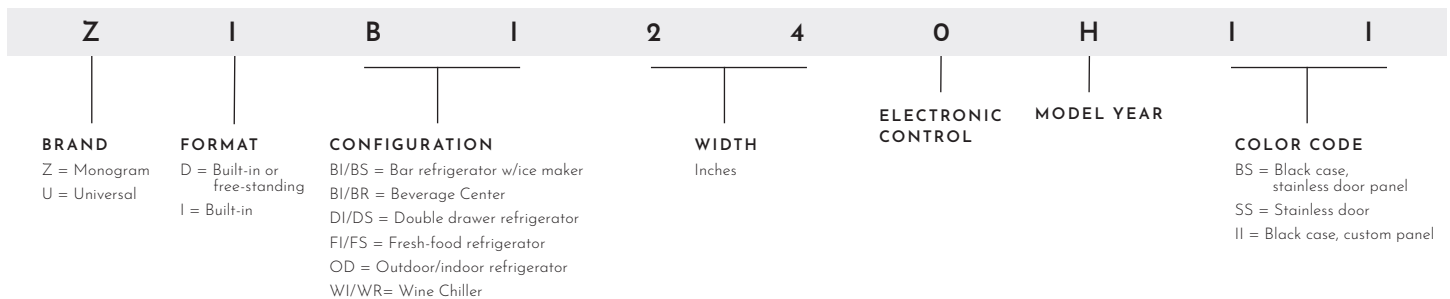

NOMENCLATURE



ICE MAKERS

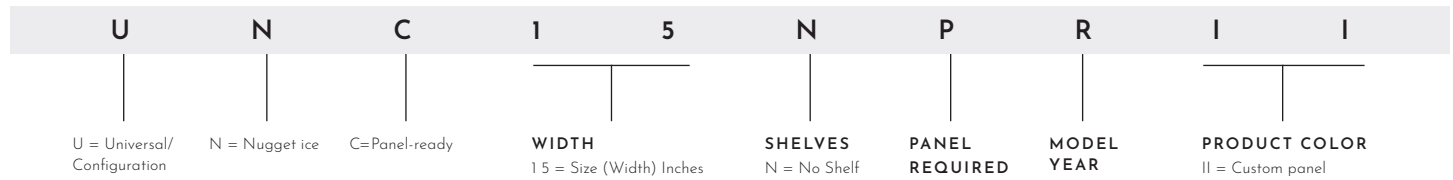

DISH WASHERS



COMPACTORS

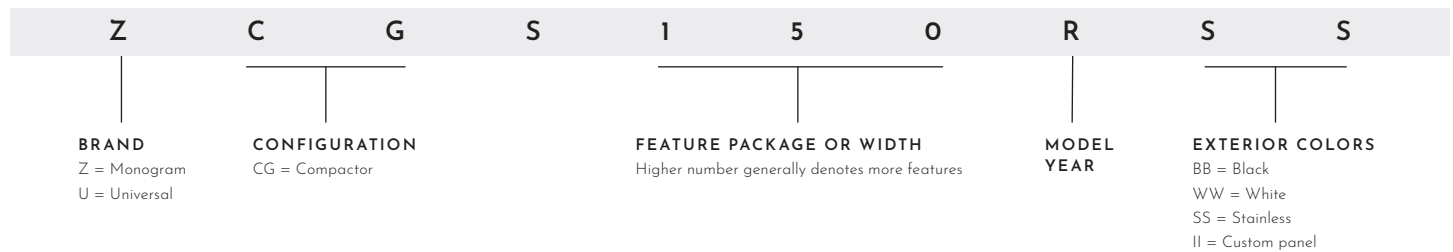

FORGE HEATED ICE PRESS

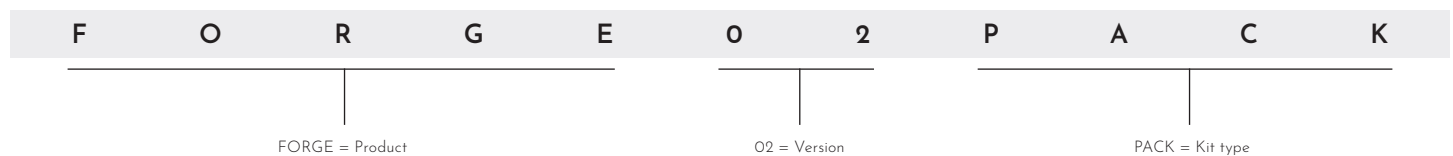

Nomenclature

Refrigeration

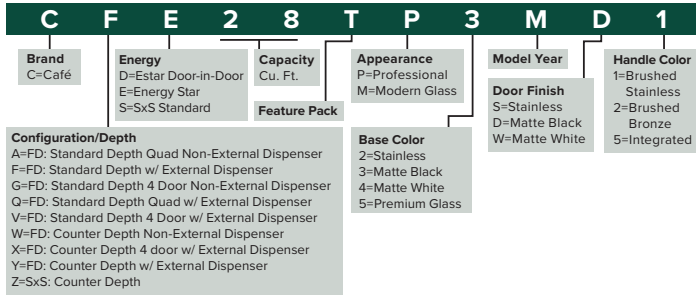

Built-In Refrigerator Drawers

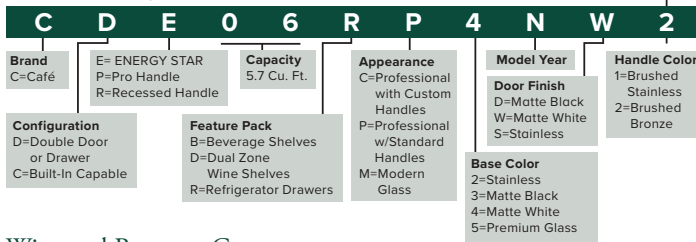

Wine and Beverage Centers

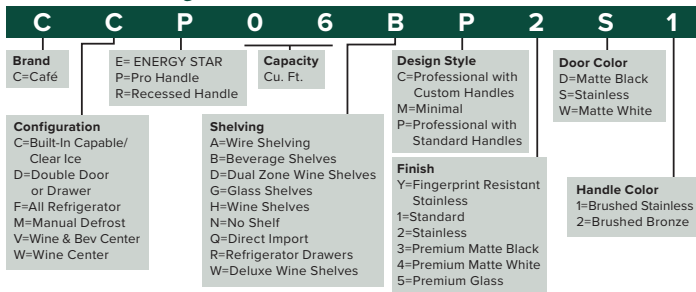

Undercounter Ice Makers

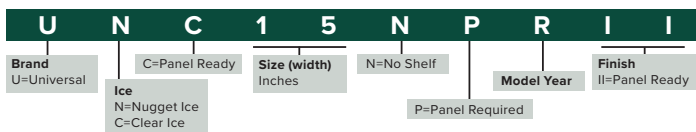

Built-In Wall Ovens

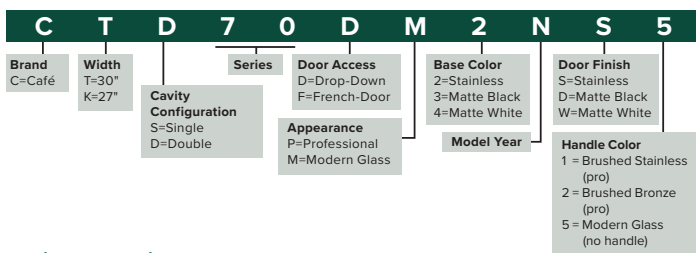

Built-In Combination Oven

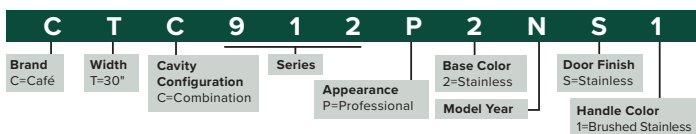

Advantium® Ovens

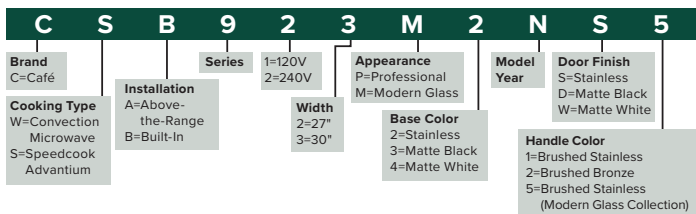

Microwave Ovens

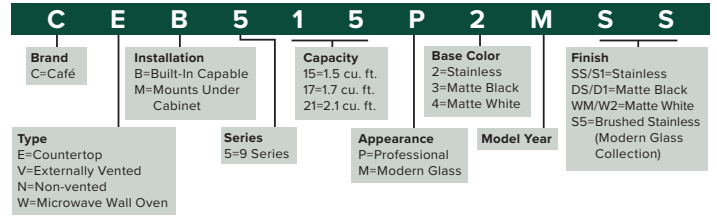

Microwave Ovens (select Countertop and Over-the-Range)

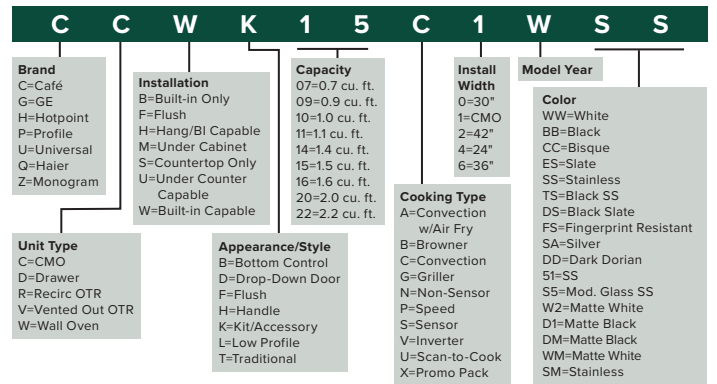

Built-In Steam Oven

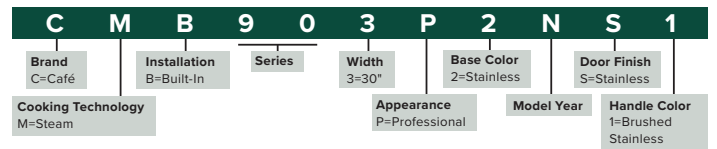

Commercial-Style Ranges and Rangetops

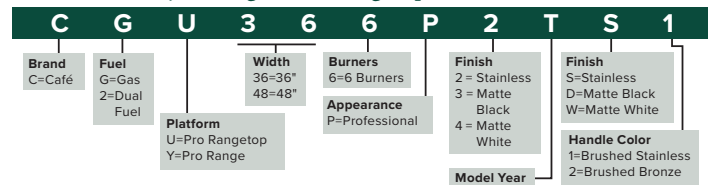

Ranges

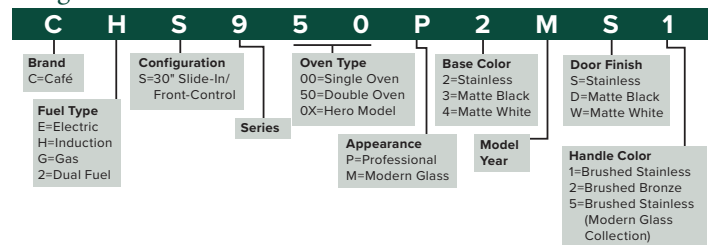

Cooktops

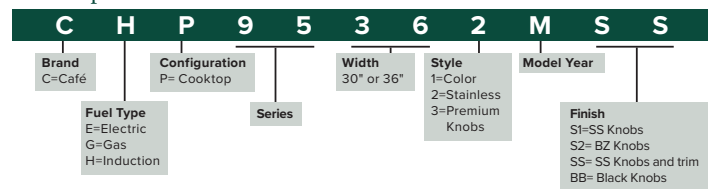

Warming Drawers

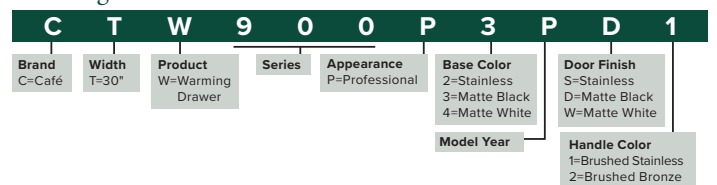

Ventilation

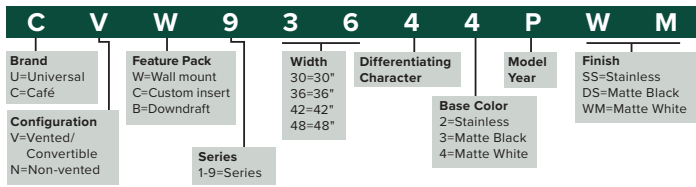

Dishwashers

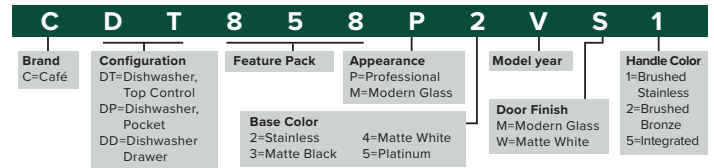

Small Appliances

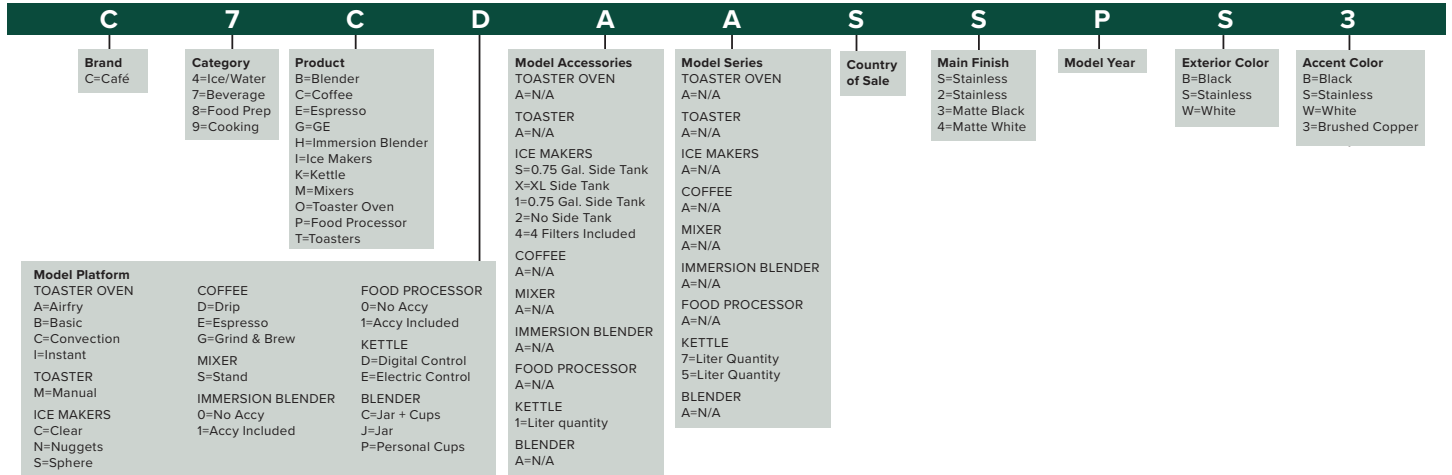

Nomenclature



FRENCH-DOOR REFRIGERATOR

P	F	E	2	8	P	S	K	S	S
Brand G=GE P=GE Profile™	Energy E=ENERGY STAR® S=Standard D=Door in door	Capacity Cubic feet	Feature Pack	Model Year	Color BB=Black CC=Bisque DS=Black Slate ES=Slate FS=Fingerprint Resistant SA=Silver SS=Stainless TS=Black Stainless WW=White	Finish G=High-gloss M=Slate S=Stainless E=Black Slate B=Black Stainless Y=Fingerprint Resistant Stainless			
Configuration/Depth V=Standard Depth, 4-Door X=Counter Depth, 4-Door G=Standard Depth, 4-Door, Dual-Dispense A=Standard Depth Quad									

BOTTOM-FREEZER REFRIGERATOR

G	D	E	2	5	E	S	K	S	S
Brand G=GE	Energy E=ENERGY STAR® S=Standard	Capacity Cubic feet	Feature Pack	Model Year	Color BB=Black CC=Bisque DS=Black Slate ES=Slate FS=Fingerprint Resistant SA=Silver SS=Stainless TS=Black Stainless WW=White	Finish G=High-Gloss M=Slate S=Stainless			
Configuration/Depth B=Bottom-freezer door, no icemaker D=Bottom-freezer drawer, with icemaker									

SIDE-BY-SIDE REFRIGERATOR

G	S	E	2	5	H	S	H	S	S
Brand G=GE P=GE Profile™	Energy E=ENERGY STAR® S=Standard	Capacity Cubic feet	Feature Pack	Model Year	Color BB=Black CC=Bisque DS=Black Slate ES=Slate FS=Fingerprint Resistant SA=Silver SS=Stainless TS=Black Stainless WW=White	Finish G=High-gloss M=Slate S=Stainless B=Black Stainless Y=Fingerprint Resistant Stainless			
Configuration/Depth S=Standard depth Z=Counter depth									

TOP-FREEZER REFRIGERATOR

G	T	E	1	5	C	T	H	R	W	W
Brand G=GE	Energy E=ENERGY STAR® S=standard	Capacity Cubic feet	Model Year	Color BB=Black CC=Bisque DS=Black Slate ES=Slate FS=Fingerprint Resistant SA=Silver SS=Stainless TS=Black Stainless WW=White	Finish C=Silver Metallic G=High-gloss M=Slate S=Stainless T=Textured	Configuration T=Top-freezer with handle, no icemaker I=Top-freezer with handle and icemaker P=Top-freezer with pocket handle, no icemaker	Feature pack C=Wire shelves, pocket handle, texture door D=Wire shelves, handle texture door G=Glass shelves, texture door H=Glass shelves, smooth door J=Premium door shelves, texture door K=Garage Ready, smooth door	Door Swing R=Right L=Left		

CHEST FREEZER

F	C	M	2	2	D	L	W	W
GE freezer	Chest	Manual	Cubic Feet	Series C=Camouflage D=Deluxe P=ENERGY STAR® S=Standard	Model Year	Color WW=White CD=Camouflage/ Dorian Grey		

UPRIGHT FREEZER

F	U	F	1	4	D	L	R	W	W
GE freezer	Upright	Frost-free	Cubic Feet	Series D=Deluxe S=Standard	Model Year	Door Swing R=Right L=Left	Color WW=White		

ICE MAKER

U	N	C	1	5	N	P	R	I
Configuration U=Universal	Ice N=Nugget ice C=Clear ice	Width (inches) C=Panel-ready	N=No shelf	Model Year	Product Color II=Panel-ready	P=Panel Required		

COMPACTS, WINE & BEVERAGE CENTERS

P	V	S	0	6	B	S	T	S	S
Brand G=GE P=GE Profile™	Energy E=ENERGY STAR® R=Recessed handle S=Full-size handle	Capacity Cubic feet	Model Year	Finish G=GE Gloss L=CleanSteel™ M=Slate S=Stainless	Color WW=White on White BB=Black on Black LB=CleanSteel ext./ Black handle SS=Stainless ext./SS handle SB=Stainless ext./ Black handle ED=Slate appearance/ Dorian Gray handle	Type C=Built-in capable D=Double door F=All refrigerator M=Manual defrost V=Wine & bev center W=Wine center	Shelving A=Wire shelves B=Beverage shelves D=Dual zone wine shelves G=Glass shelves V=Wine shelves W=Deluxe wine shelves		

WALL OVEN

P	T	S	7	0	0	0	B	N	T	S
Brand G=GE Profile™ J=GE	Width T=30" K=27"	Cavity Configuration S=Single D=Double	Series	Door style O=Drop down L=Left-hand swing R=Right-hand swing	Base color D=Color match S=Stainless B=Black E=Slate F=Black Slate	Model Year	Finish SS=Stainless TS=Black ES=Stainless DS=Black BB=Black WW=White			

WARMING DRAWER

P	T	W	9	0	0	0	S	N	S	S
Brand P=GE Profile™	Width T=30" K=27"	Configuration W=Warming drawer	Series	Base Color S=Stainless	Model Year	Product Color SS=Stainless				

ADVANTUM® (2008 and beyond)

P	S	B	9	2	0	1	S	F	S	S
Brand P=GE Profile™	Configuration A=Above-the-cooktop B=Built-in wall oven	Voltage 1=120 volt 2=240 volt	Model/Door color S=Stainless E=Slate B=Black Stainless	Product color SS=Stainless ES=Slate TS=Black Stainless	Feature pack Designates features—the higher the number, the more features.	Model Year				
GE Speedcook Technology										

OVER-THE-RANGE AND COUNTERTOP MICROWAVE OVENS

P	V	M	9	2	1	5	S	K	S	S
Brand P=GE Profile™ J=GE	Installation B=Built-in capability M=Mounts under cabinet S=Countertop only	Series	Feature pack Designates features—the higher the number, the more features.	Capacity XX=cubic feet	Model Year	Color WW=White on White BB=Black on Black CC=Bisque on Bisque SS=Stainless ES=Slate TS=Black Stainless DS=Black Slate FS=Fingerprint Resistant Stainless	Type E=Countertop V=Externally vented, over-the-range N=Non-vented, over-the-range W=Microwave wall oven	Model/Door color D=Color-matched S=Stainless with Gray B=Black Stainless R=Stainless with Black E=Slate M=Silver F=Black Slate Y=Fingerprint Resistant Stainless		

MICROWAVE OVEN (SELECT COUNTERTOP AND OVER-THE-RANGE)

G	R	M	T	1	6	N	O	R	1	W	W
Brand C=Café G=GE H=Hotpoint P=Profile U=Universal Q=Haier Z=Monogram	Installation B=Built-in Only F=Flush H=Hang/BI Capable M=Under Cabinet S=Countertop Only U=Under Counter Capable W=Built-in Capable	Capacity Cu. Ft. 07=0.7 09=0.9 10=1.0 11=1.1 14=1.4 15=1.5 16=1.6 20=2.0 22=2.2	Install Width 0=30" 1=CMO 2=42" 4=24" 6=36"	Engineering Suffix	Model Year	Color WW=White BB=Black CC=Bisque ES=Slate SS=Stainless TS=Black SS=Stainless DS=Black Slate FS=Fingerprint Resistant SA=Silver DD=Dark Dorian 51=SS S5=Mod. Glass SS W2=Matte White D1=Matte Black DM=Matte Black WM=Matte White SM=Stainless	Unit Type C=CMO D=Drawer R=Recirc OTR V=Vented Out OTR W=Wall Oven	Appearance/Style B=Bottom Control D=Drop-Down Door F=Flush H=Handle K=Kit/Accessory L=Low Profile T=Traditional	Cooking Type A=Convection w/Air Fry B=Browner C=Convection G=Griller N=Non-Sensor S=Sensor V=Inverter U=Scan-to-Cook X=Promo Pack		

Nomenclature



GE APPLIANCES



Profile™

COOKTOP

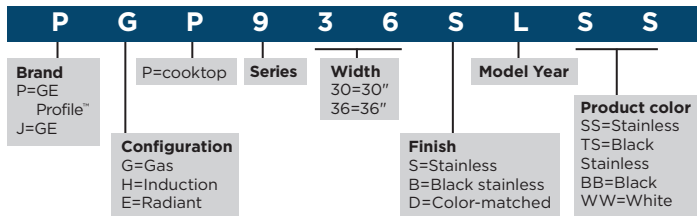

RANGES

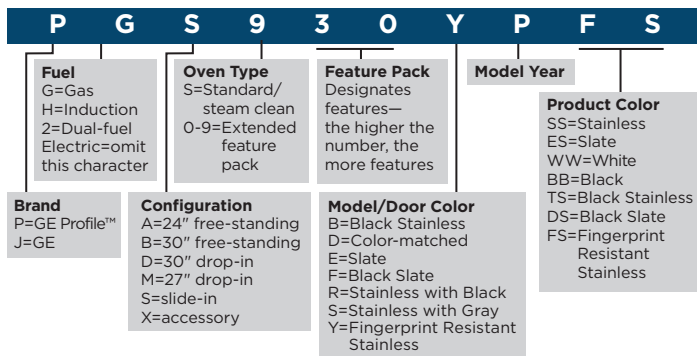

RANGES SELECT GE RANGES

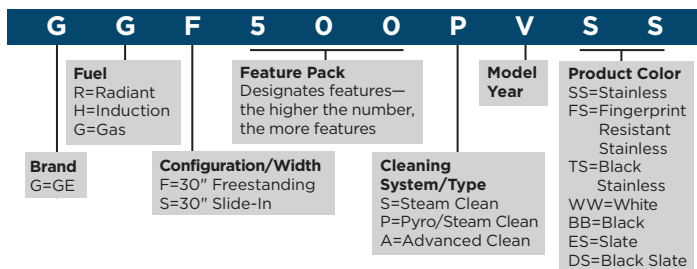

VENTILATION

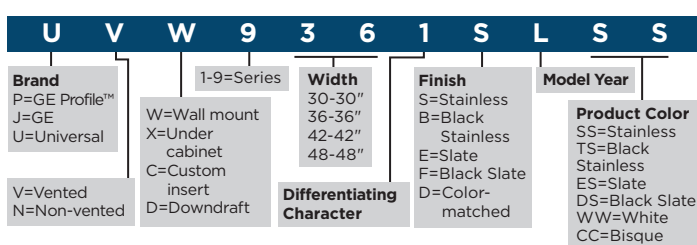

DISHWASHER STAINLESS STEEL, HYBRID STAINLESS STEEL & PLASTIC INTERIOR

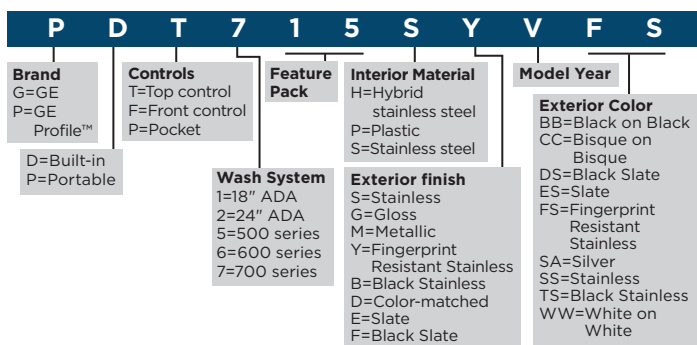

DISPOSER



WASHER

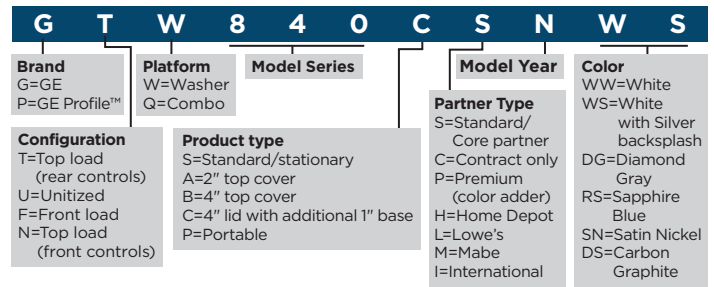

DRYER

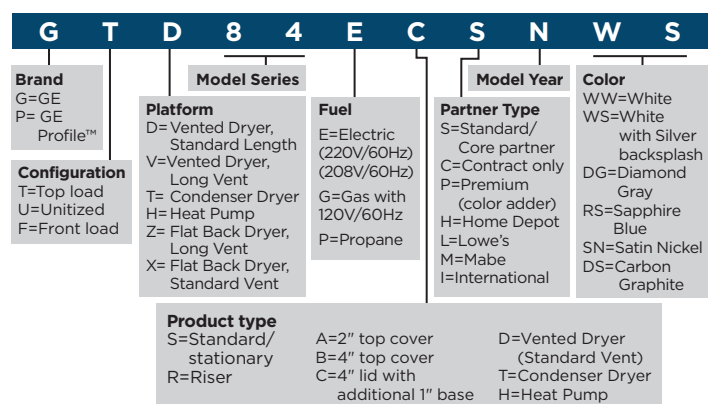

WATER SOFTENING SYSTEM

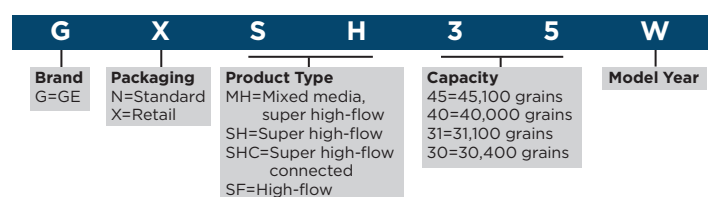

FLEXIBLE CAPACITY ELECTRONIC WATER HEATER

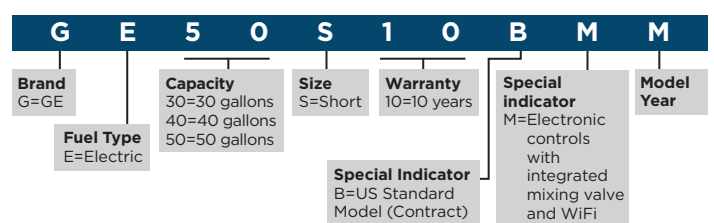

ELECTRIC TANKLESS WATER HEATER

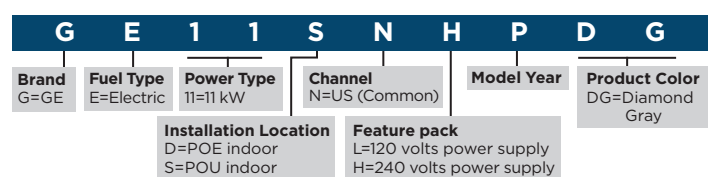

SOLAR WATER HEATER

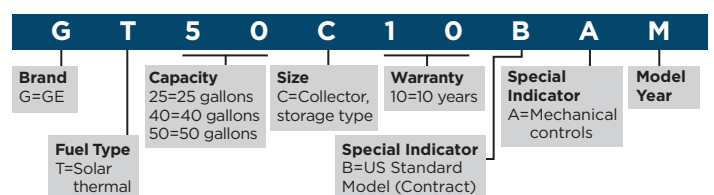

Nomenclature



ELECTRONIC/ELECTRIC WATER HEATER

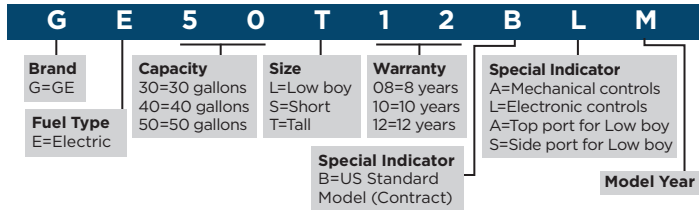

ELECTRIC POINT-OF-USE WATER HEATER

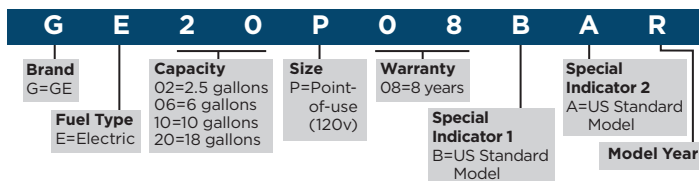

GAS WATER HEATER

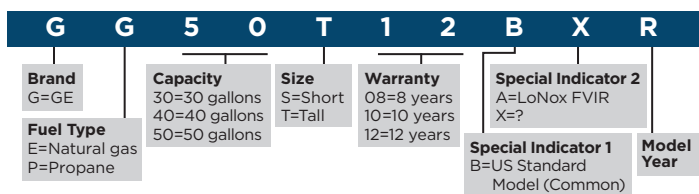

REVERSE OSMOSIS FILTRATION SYSTEM

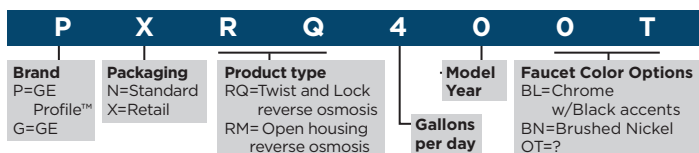

UNDER-SINK FILTRATION SYSTEM

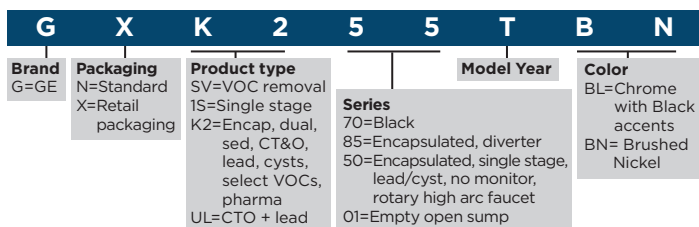

INLINE FILTRATION

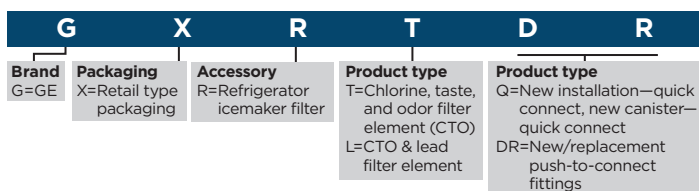

WHOLE HOUSE SMART VALVE WITH FILTRATION

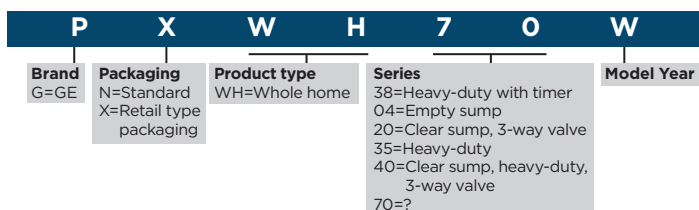

WINDOW AIR CONDITIONER

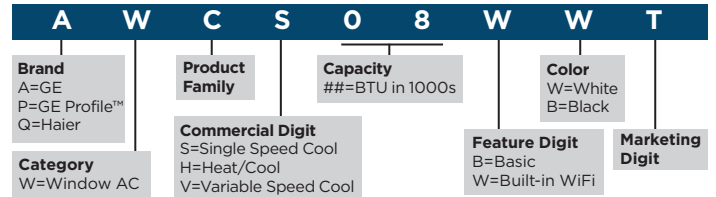

PORTABLE AIR CONDITIONER

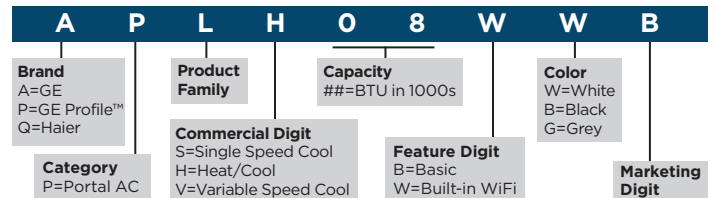

DEHUMIDIFIER

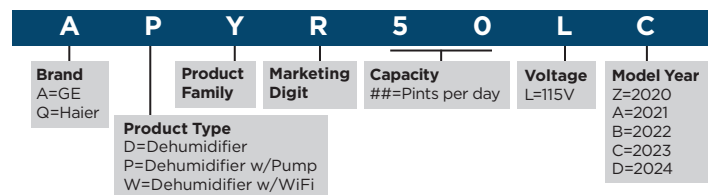

BUILT-IN/THROUGH-THE-WALL AIR CONDITIONER

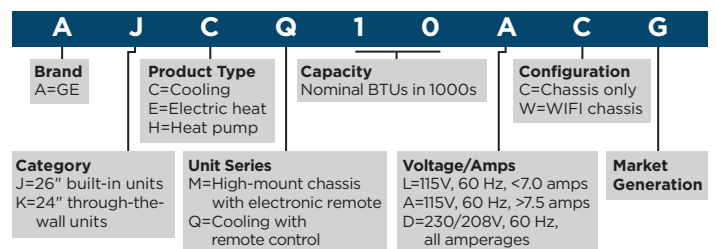

ZONELINE® CHASSIS

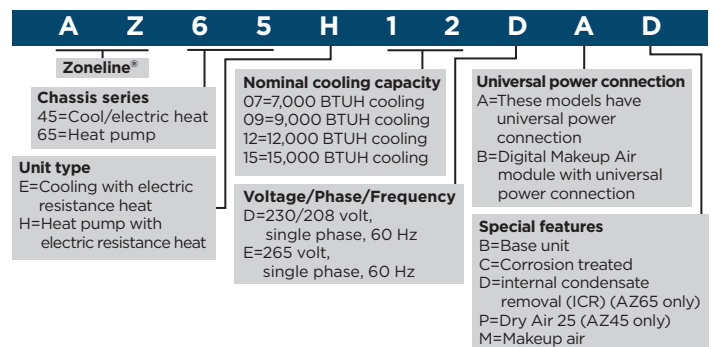

ZONELINE® VERTICAL UNIT

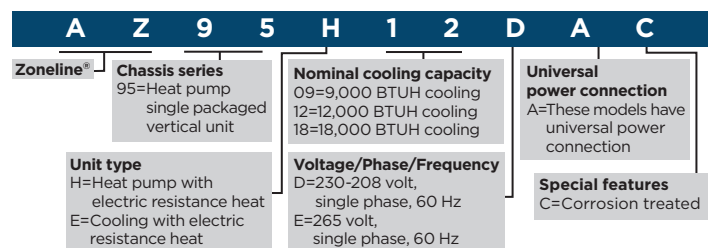

SMALL APPLIANCES

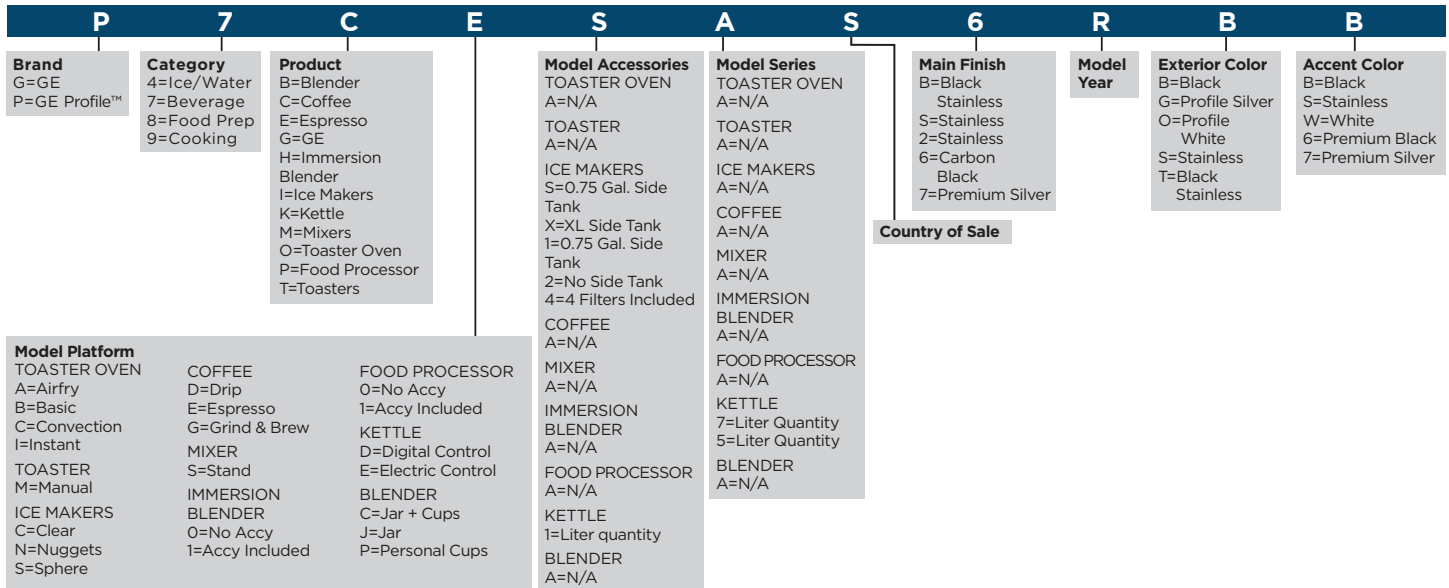

OPAL 01

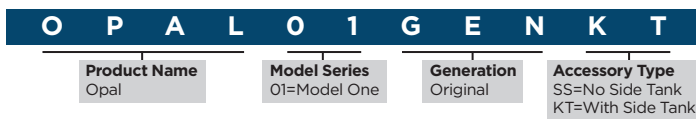

OPAL 2.0

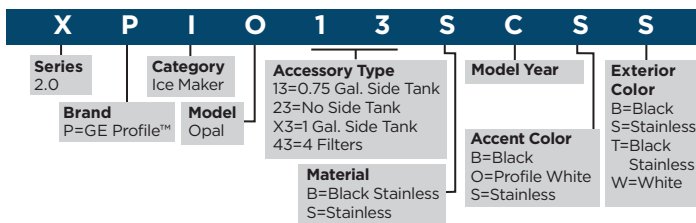

SMART MIXER

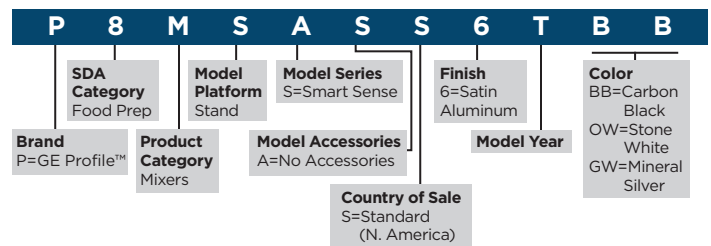

Nomenclature



REFRIGERATION

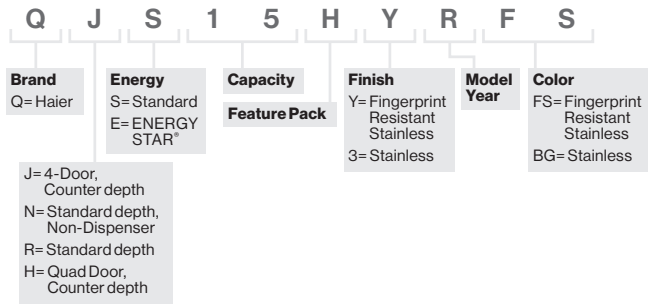

RANGES

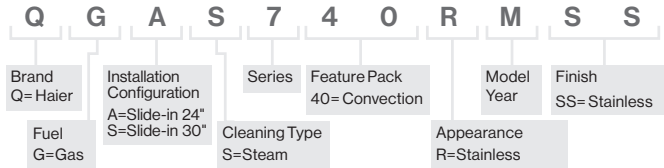

BUILT-IN COOKING & VENTILATION

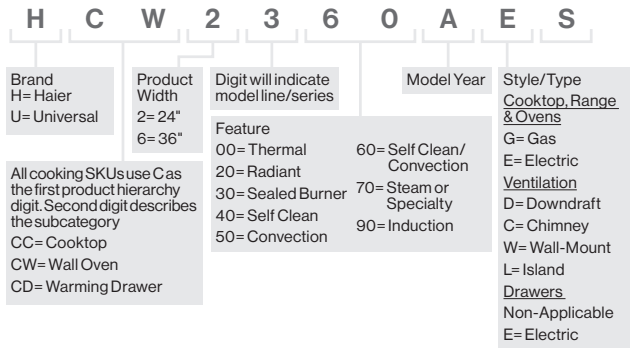

OVER-THE-RANGE MICROWAVE

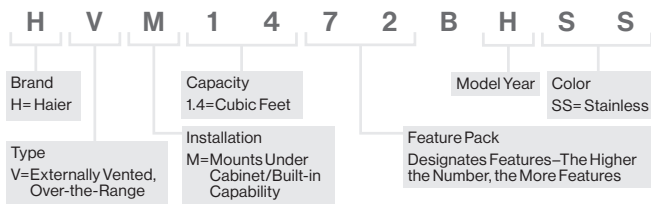

DISHWASHER

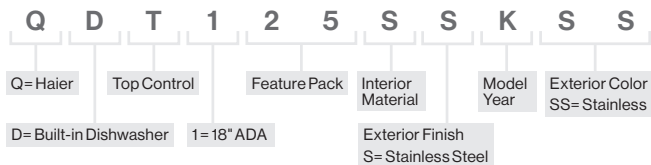

WINDOW AIR CONDITIONER

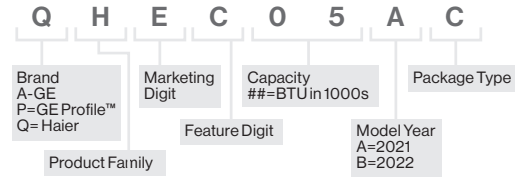

PORTABLE AIR CONDITIONER

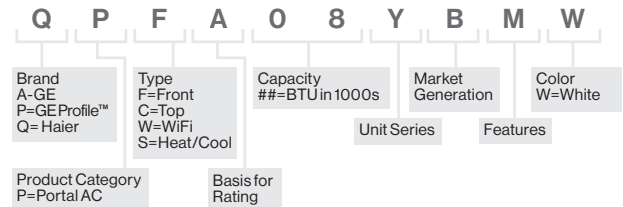

DEHUMIDIFIER

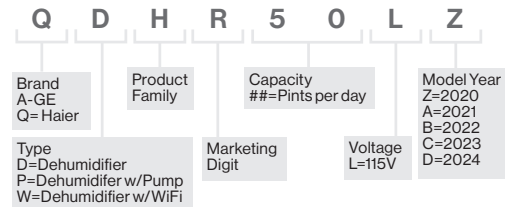

Nomenclature



TOP-FREEZER REFRIGERATOR

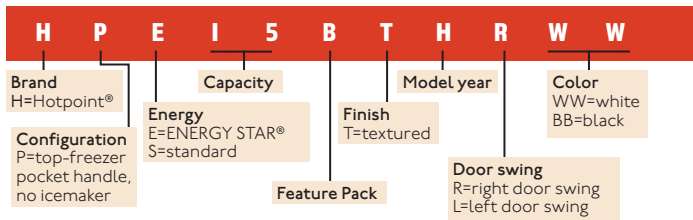

COMPACT REFRIGERATOR

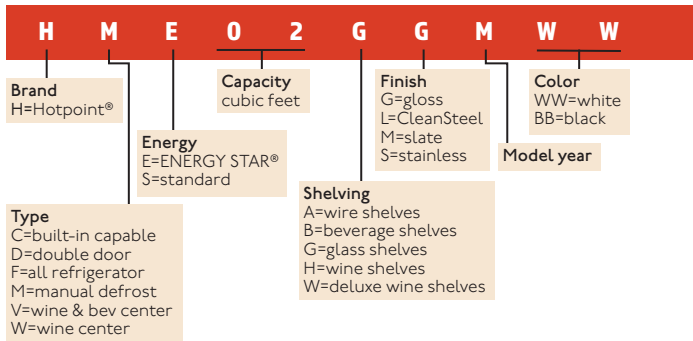

FREEZER

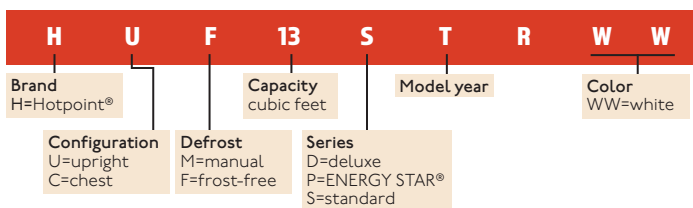

DISHWASHER

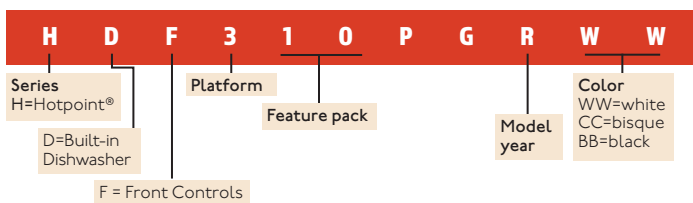

PTAC

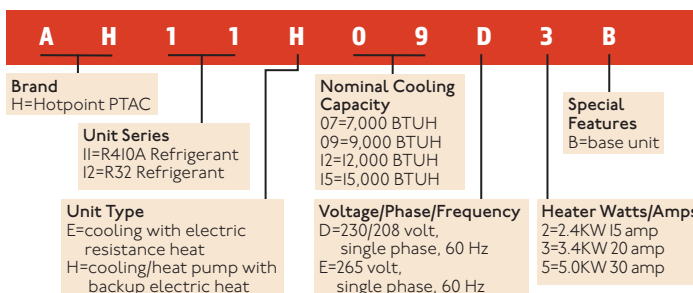

RANGES

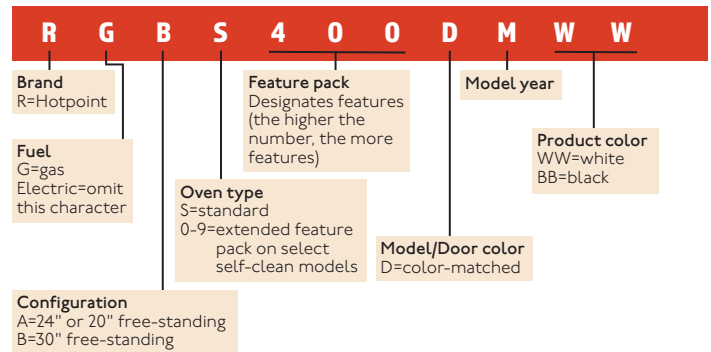

OVER-THE-RANGE MICROWAVE OVEN

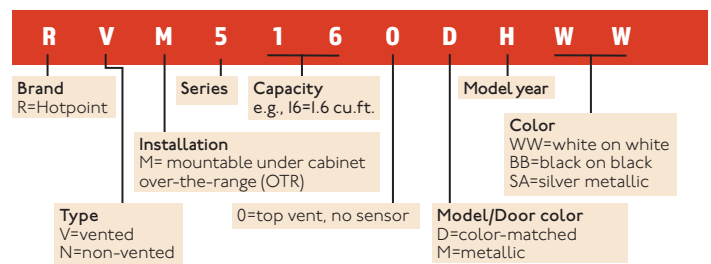

WASHER

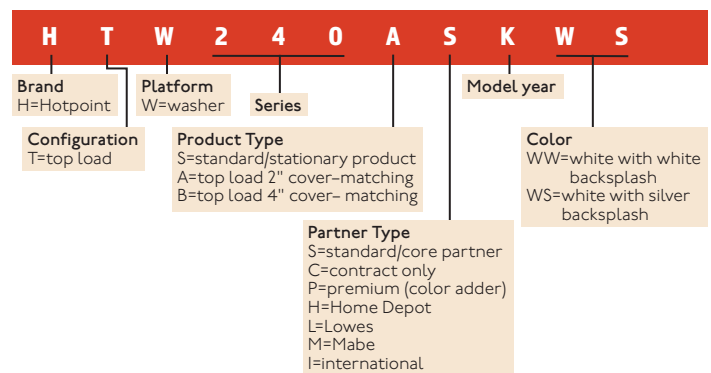

DRYER

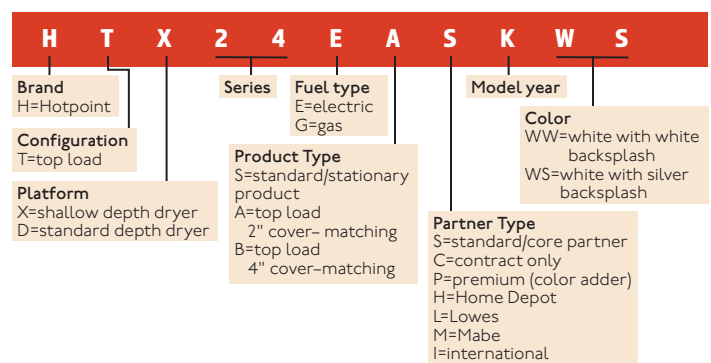

Nomenclature



GE WATER SOFTENERS

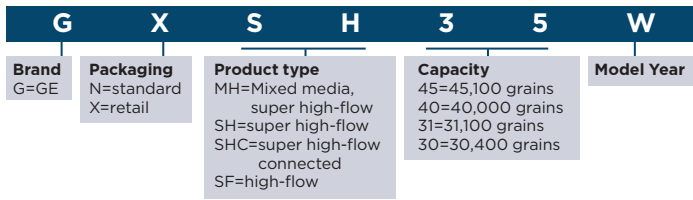

GE FLEXIBLE CAPACITY ELECTRONIC WATER HEATER

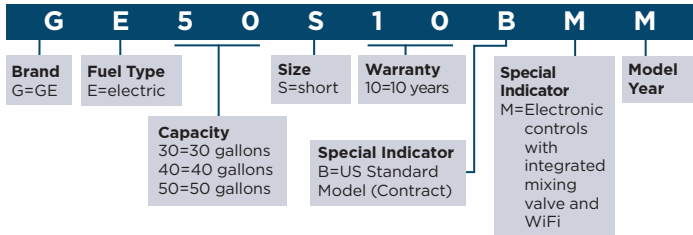

GE TANKLESS ELECTRIC WATER HEATER

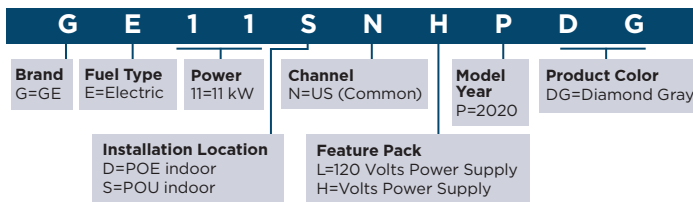

GE SOLAR WATER HEATER

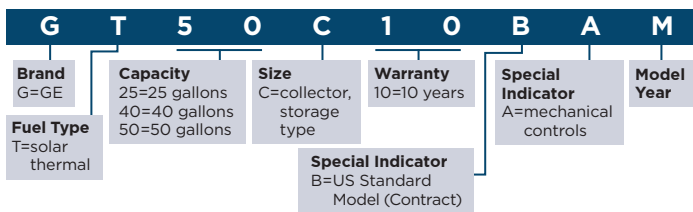

GE DISPOSER

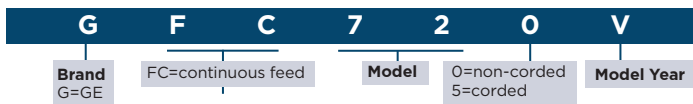

GE ELECTRONIC/ELECTRIC WATER HEATER

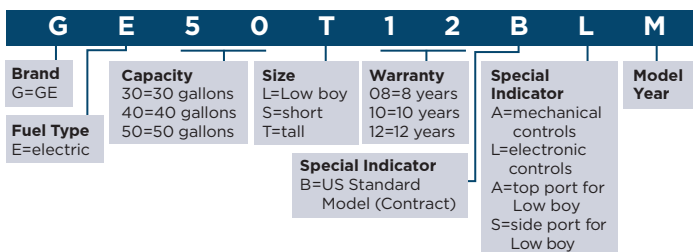

GE ATMOSPHERIC GAS WATER HEATER

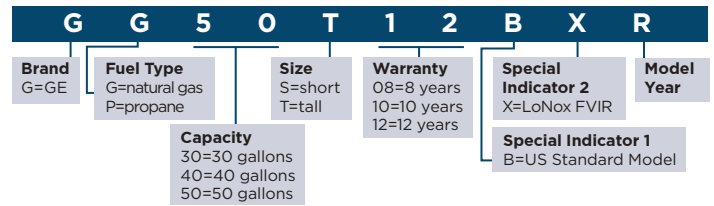

GE ELECTRIC POINT OF USE WATER HEATER

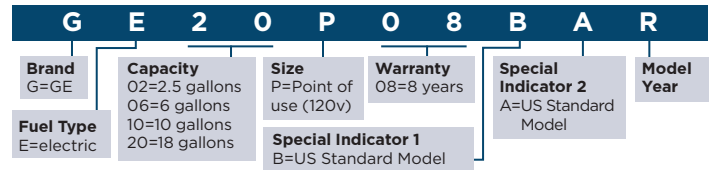

GE REVERSE OSMOSIS FILTRATION SYSTEM

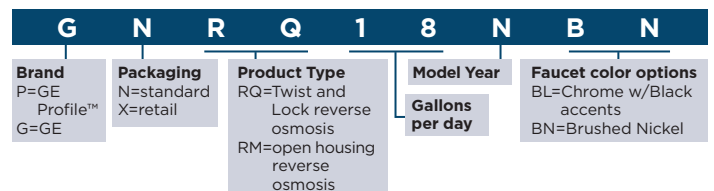

GE UNDER SINK FILTRATION SYSTEM

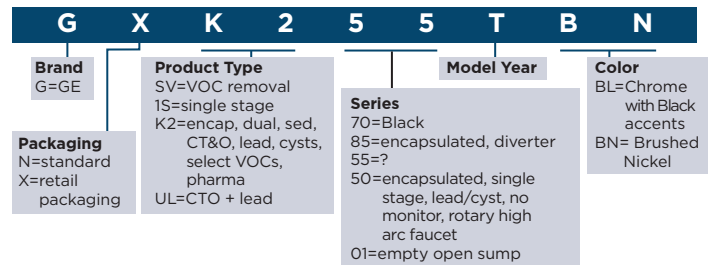

GE INLINE FILTRATION

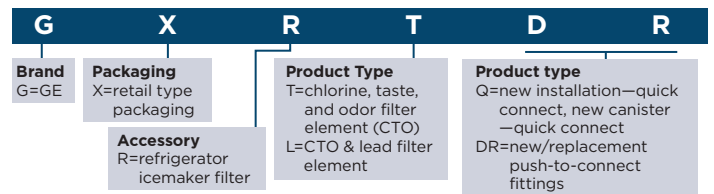

GE PROFILE WHOLE HOUSE SMART VALVE WITH FILTRATION

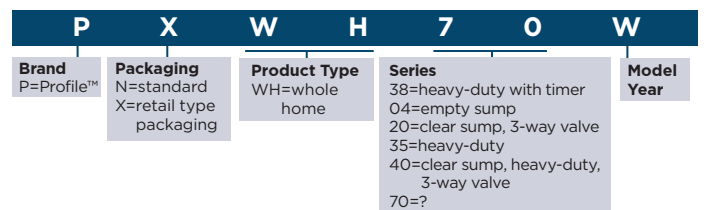

Nomenclature



GE PORTABLE AIR CONDITIONER

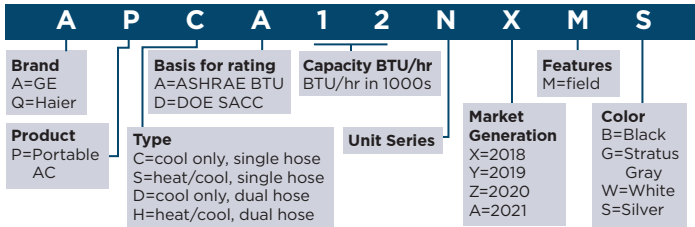

WINDOW AIR CONDITIONER

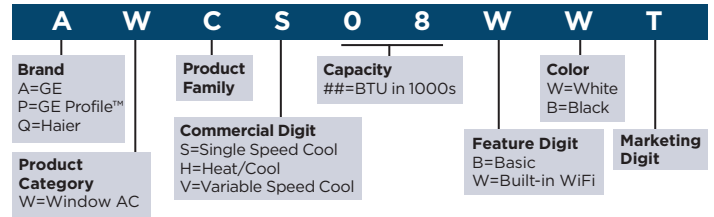

GE BUILT-IN/THROUGH-THE-WALL AIR CONDITIONER

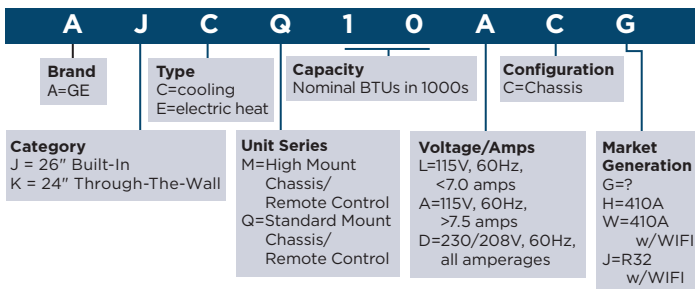

PORTABLE AIR CONDITIONER

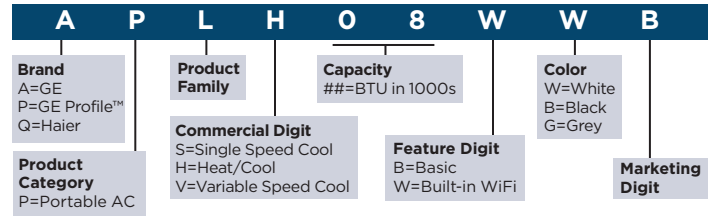

DEHUMIDIFIER

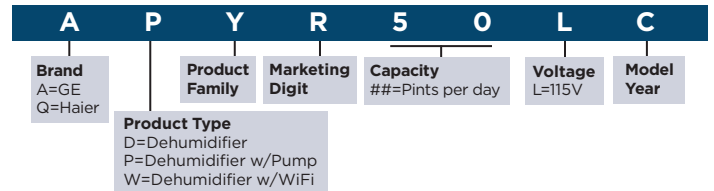

GE ZONELINE® PTAC

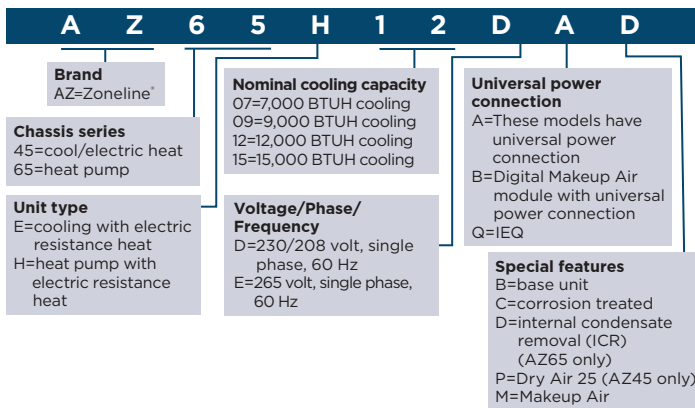

GE ZONELINE® VERTICAL

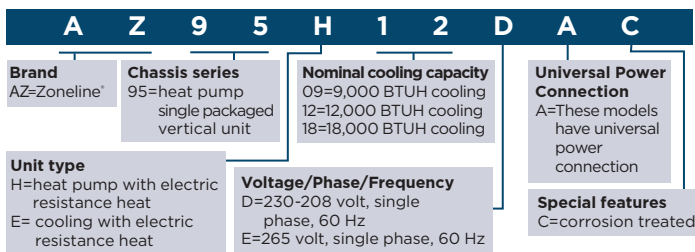

HOTPOINT® PTAC

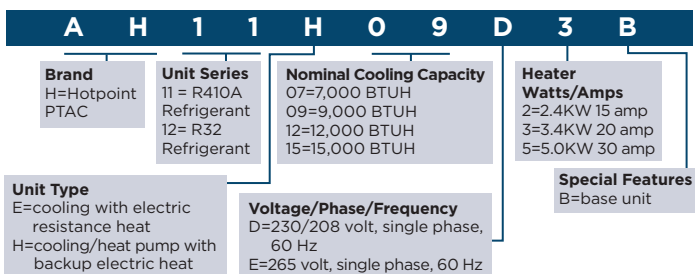

Nomenclature



GE APPLIANCES
a Haier company

AIR & WATER
SOLUTIONS

GE® OUTDOOR SPLITS

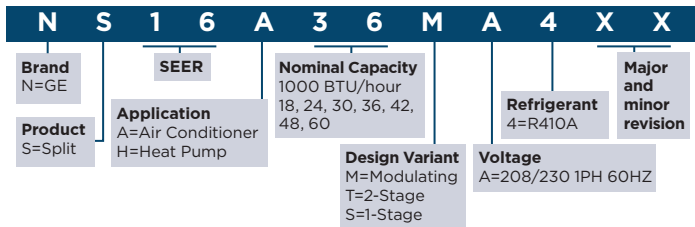

GE FURNACE

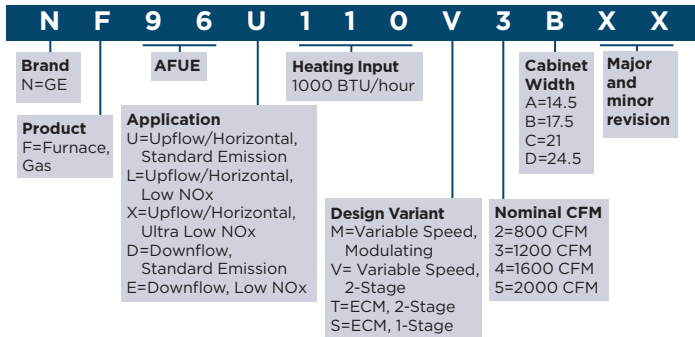

GE COIL

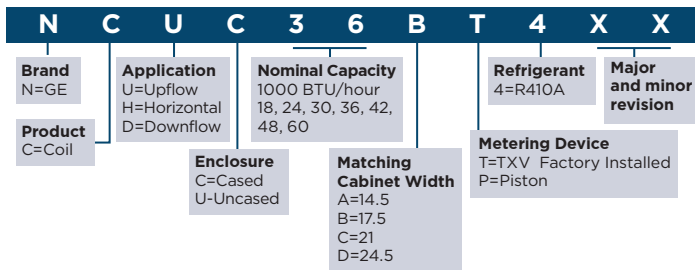

GE AIR HANDLER

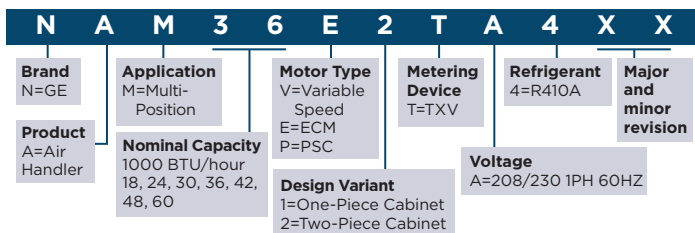

GE DUCTLESS HVAC

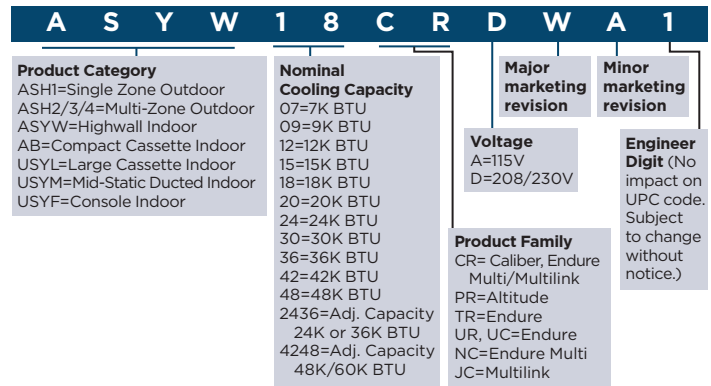

HAIER® DUCTLESS HVAC

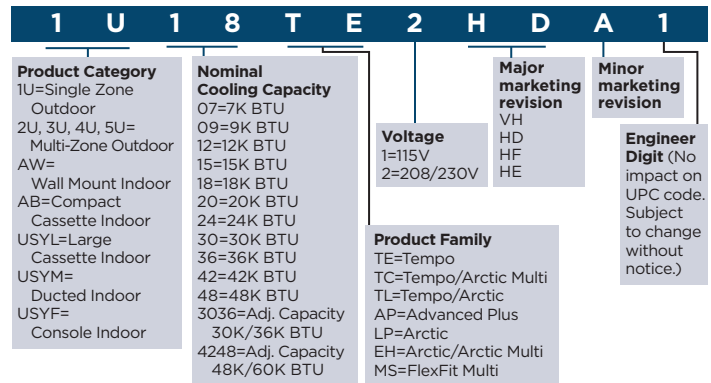

VRF OUTDOOR UNITS

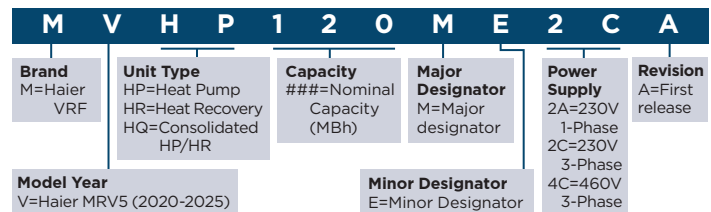

VRF INDOOR UNITS

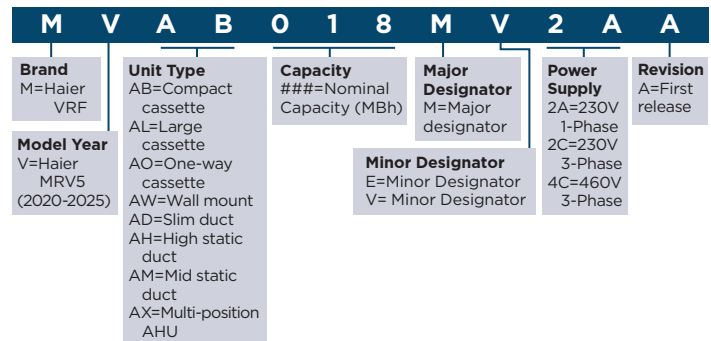



GE APPLIANCES
a Haier company

GE is a trademark of the General Electric Company.
Manufactured under trademark license.

GE Appliances has a policy of continuous improvement
of its products and reserves the right to change
materials and specifications without notice.

WARMING ZONE

FEBRUARY 2024 PS125606